

BC brushless driver instruction manual

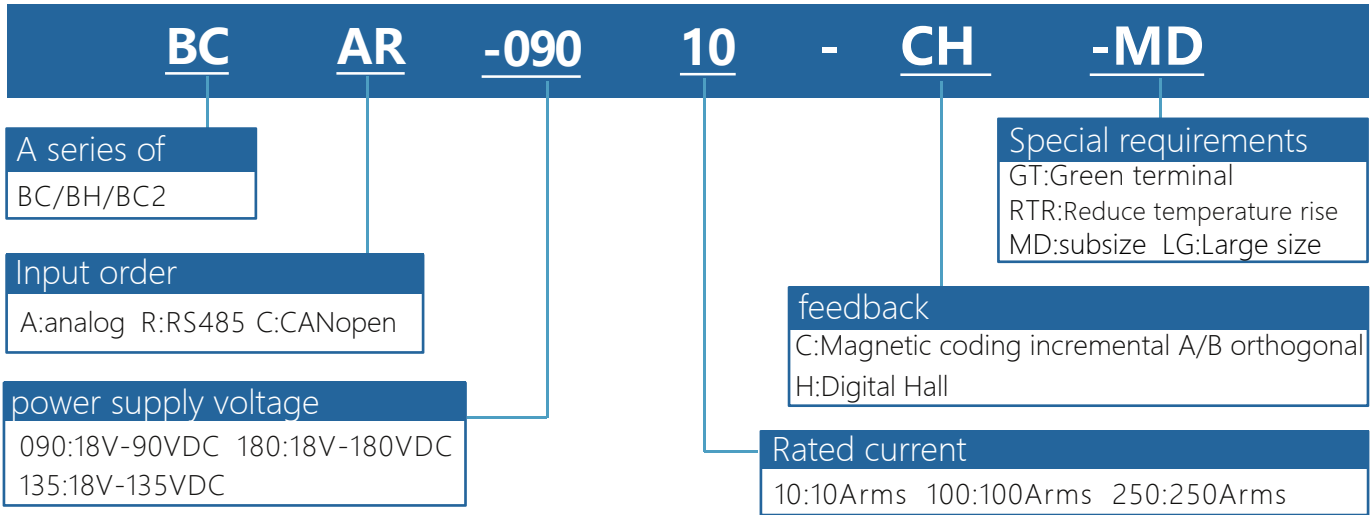

BC Brushless drive model description



Attention to:

1.The driver supply voltage must be greater than or equal to the rated voltage of the motor

2.The rated current of the driver must be greater than or equal to the rated current of the motor

BC brushless drive specification summary table

Driver model	service voltage	Rated current Arms	Peak current Apk6S rms	Feedback type	Overall dimensions	weight
BCAR-09002-CH	18-90VDC	2A	6A	Digital Hall + Encoder ABZ	141*90*32mm	0.35kg
BCAR-09005-CH		6A	18A			
BCAR-09010-CH		11A	33A			
BCAR-09015-CH		16A	50A			
BCAR-09020-CH		21A	50A			
BCAR-09030-CH		30A	60A		167*100*35mm	0.45kg
BCAR-09035-CH		35A	70A			
BCAR-09050-CH		50A	100A			
BCAR-09070-CH		70A	140A			
BCAR-09085-CH		85A	170A			
BCAR-090100-CH		100A	200A		221*140*59mm	1.45kg
BCAR-090140-CH		140A	280A			
BCAR-090210-CH-MD		210A	300A			
BCAR-090210-CH-LG		210A	300A			
BCAR-090250-CH		250A	330A			
BCAR-18015-CH	18-180VDC	16A	32A	Digital Hall + Encoder ABZ	167*100*35mm	0.45kg
BCAR-18035-CH		35A	70A		200*114*59mm	1.10kg
BCAR-18050-CH		50A	100A		221*140*59mm	1.45kg
BCAR-18070-CH		70A	140A		265*140*85mm	2.2kg
BCAR-180100-CH		100A	200A		221*140*59mm	1.45kg
BCAR-13570-CH	18-135VDC	70A	140A	Digital Hall + Encoder ABZ	221*140*59mm	1.45kg
BCAR-135100-CH		100A	200A		221*140*85mm	1.8kg
BCAR-135140-CH		140A	200A		265*140*85mm	2.2kg
BCAR-125210-CH		210A	300A		221*140*85mm	1.8kg

BC series terminal definition

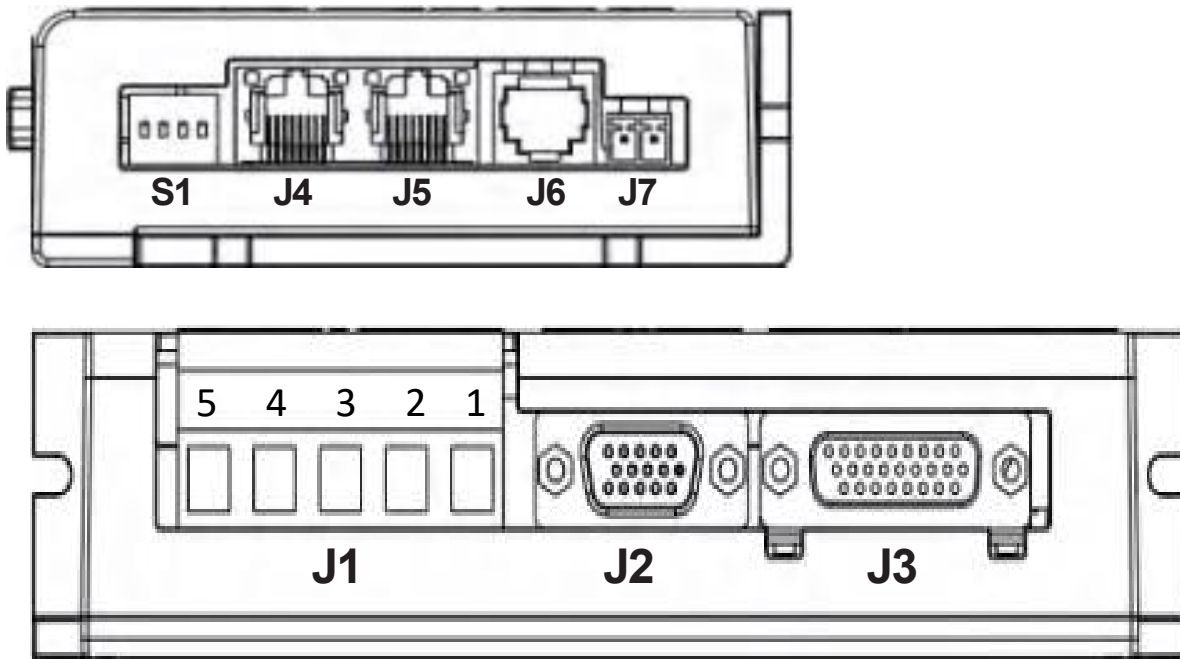

BC series dimensions drawing

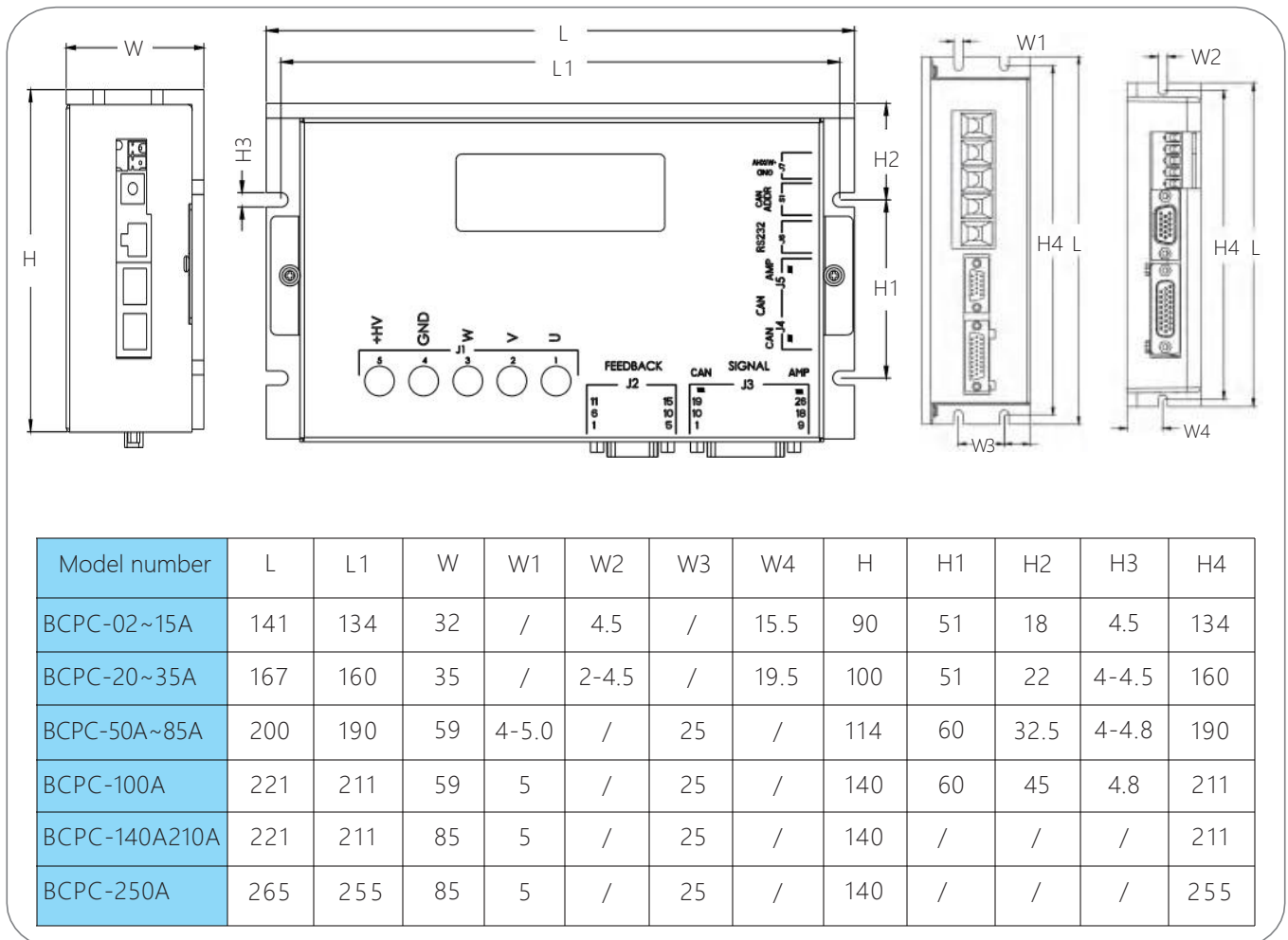

1、 Product introduction:

1.1 An overview of the

The BC Series Brushless drive is a versatile, high-performance, DC-powered, compact, all-digital brushless drive. Support brushless motor speed, torque control. Can support non-inductive and inductive (incremental encoder, digital Hall);

1.2 Technical characteristics

- ◆Control mode: speed, torque;
- ◆Programmable protection: over current, over voltage or under voltage, I^2t , output short circuit, overload and other multi-directional protection functions;
- ◆Drive motor type: brushless motor (non-inductive and inductive);
- ◆Feedback: Digital Hall, incremental encoder (optional).
- ◆Communication mode:
 1. RS232 serial interface, baud rate up to 115KB;
 2. RS485 MODBUS RTU serial interface, baud rate up to 115KB;
 3. CAN communication, compatible with CANopen DS-402, baud rate up to 1MHz ;
(Only one RS485 or CAN can be selected)
- ◆Power supply voltage: 18-90(135/180)VDC;

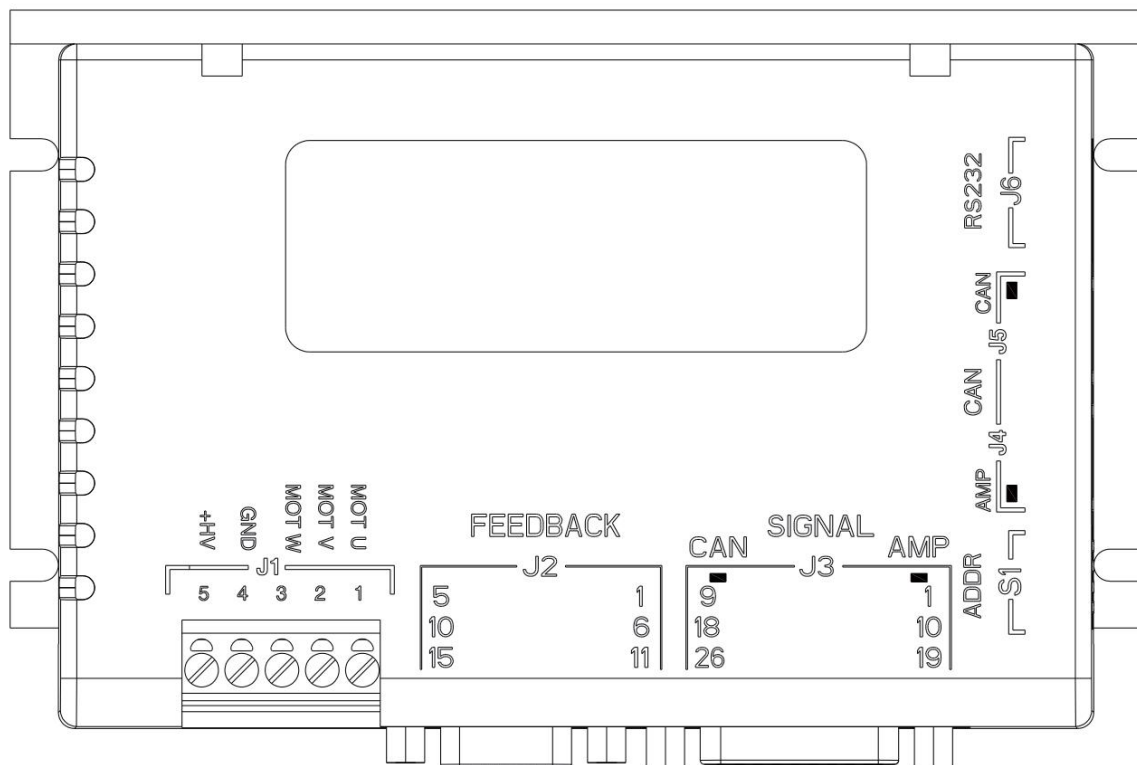

1.3 BC Brushless drive electrical specifications

Speed control	Command control mode		$\pm 10V$ analog, PWM, CANOpen, RS485 MODBUS RTU, pulse	
	input signal	PWM	polarity	PWM=0~100%, polarity=1/0
			nonpolar	PWM=50% +/-50%,
			Frequency range	Minimum 1 kHz, maximum 100 kHz
			Minimum pulse width	220ns
	Analog instruction	Voltage range	Input voltage range $\pm 10V$	
impedance		Differential input impedance =5K Ω		
Current control	Command control mode		CANOpen, RS485 MODBUS RTU	
	input signal	PWM	polarity	PWM=0~100%, polarity=1/0
			nonpolar	PWM=50% +/-50%,
			Frequency range	Minimum 1 kHz, maximum 100 kHz
			Minimum pulse width	220ns
	Analog instruction	Voltage range	Input voltage range $\pm 10V$	
impedance		Differential input impedance =5K Ω		
I/O signal	Digital input IN		Number of Ports	4 (where pin 9 AREF-, pin 10 AREF+).
			Settable function	IN1 Hardware enable, IN2 single-phase analog direction (F/R), IN3 PWM Direction (DRI), IN4 PWM(PUL)
	Digital output OUT		Settable function	2
			Settable function	OUT1 Fault Output (ERR), OUT2 Lock Output (BRK)
function	LED indicator		Drive status indication, communication indication	
	Communi- cations functions	RS-232	Baud rate	9600-115200
			agreement	Full duplex mode, ASCII or binary format
		RS485	Baud rate	9600-115200
			agreement	MODBUS RTU
		CAN	Baud rate	20kbit/s-1Mbit/s
			agreement	Canopen application layer DS-301V4.02
	equipment		Dsp-402 device driver and motion control	
	Protection function		Over voltage, over current, under voltage, over load, over heat, abnormal encoder, Equal protection.	
	Use environment	installation location		Non-corrosive gas, flammable gas, etc
altitude		Below 1000 m		
temperature		0°C~+50°C		
humidity		5%~95%RH, No condensation of water droplets		
Resistance to vibration/impact		Less than 4.9m/s ² / less than 19.6m/s ²		

2. Definition of wiring port

2.1 Power input terminal J1

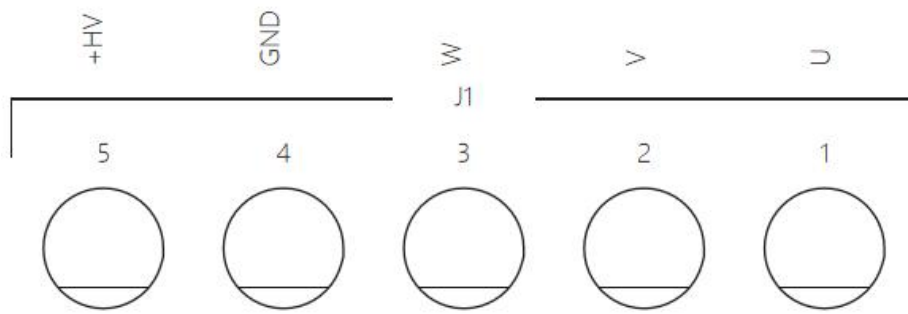

Figure 2.1 Ohm gauge terminal receptacle

serial number	define	terminal	Wiring instructions
1	U	Motor power line U phase	Must be connected to the motor one by one according to the label
2	V	Motor power line V phase	
3	W	Motor power line W phase	
4	GND	Input power -	+18~90(135/180)VDC
5	+HV	Input power +	

2.2 Motor encoder input terminal J2

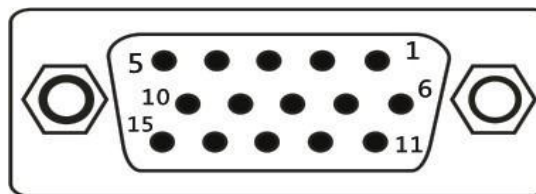

Figure 2.2 three rows of DB15 female seats

pin	define	function	pin	define	function
1	NTC*	NTC resistance temperature sensor wiring	9	W+	Motor encoder W+ input
2	NTC*		10		
3	U+	Motor encoder U+ input	11	B-	Motor encoder B- input
4	+5V	Motor signal line +5V	12	B+	Motor encoder B+ input
5	0V	Motor signal cable GND	13	A-	Motor encoder A- input
6	V+	Motor encoder V+ input	14	A+	Motor encoder A+ input
7			15	IN5*	Temperature switch sensor wiring
8					

Note: 1. *If you need Need NTC resistance temperature sensor input function, order please indicate;
 2. *If the temperature switch sensor input function is required, connect to pin 1 and pin 15, order please indicate

2.3 Control signal I/O terminal J3

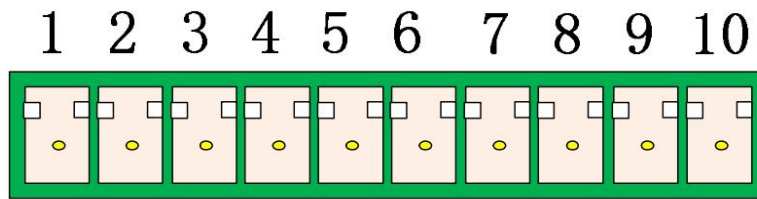

Figure 2.3 Control signal I/O terminal J3

pin	define	function
1	OUT2	Lock output (BRK)
2	OUT1	fault output (ERR)
3	IN2	Single-phase analog direction (F/R)
4	IN10(HS)	PWM direction (DRI)
5	IN9(HS)	PWM(PUL)
6	IN1	enable (EN)
7	+5V	5V output (+5V)
8	GND	Gnd
9	AREF-	Analog quantity- (AREF-)
10	AREF+	Analog quantity+ (AREF+)

2.4 CAN (RS485)communication terminal J4&J5

The driver communication port has two kinds, one is the crystal head, the other is the 6p terminal, defined as follows

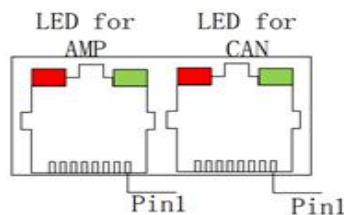

Figure 2.4 RJ45 8-pin crystal socket

RJ45Defined as follows

pin	definition	function
1	CANH (RS485_A)	CANH signal(RS485_A)
2	CANL (RS485_B)	CANL signal(RS485_B)
3/7	GND	Communication power grounding

Note: The two RJ45 ports in J4/J5 are defined in the same way to facilitate bridging during communication.

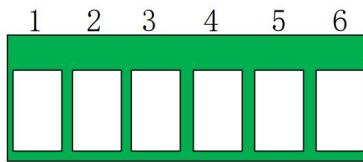

Figure 2.4.2 6P terminal

6P wiring terminals are defined as follows

pin	definition	function
1	CANH (RS485_A)	CANH signal(RS485_A)
2	CANH (RS485_A)	CANH signal(RS485_A)
3	C_GND	communicatively
4	C_GND	communicatively
5	CANL(RS485_B)	CANL signal(RS485_B)
6	CANL(RS485_B)	CANL signal(RS485_B)

3、 Definition of indicator Status

3.1 Drive status indicator (AMP)

Red/green leds tell us the status of the drive by changing color and blinking or not. Possible scenarios include:

Green/no flash	drive is OK and enabled
Green/Slow blinking	drive is OK but not enabled. After enabled, it can run
Green/Flash	Positive limit switch or negative limit switch is effective, the motor will only move in the direction not prohibited by the limit switch
Red/Fixed	Instantaneous failure, after troubleshooting amplifier restart operation
Red/flashing	Lock the fault and restart the amplifier to resume operation

3.2 CAN Communication indicator (CAN)

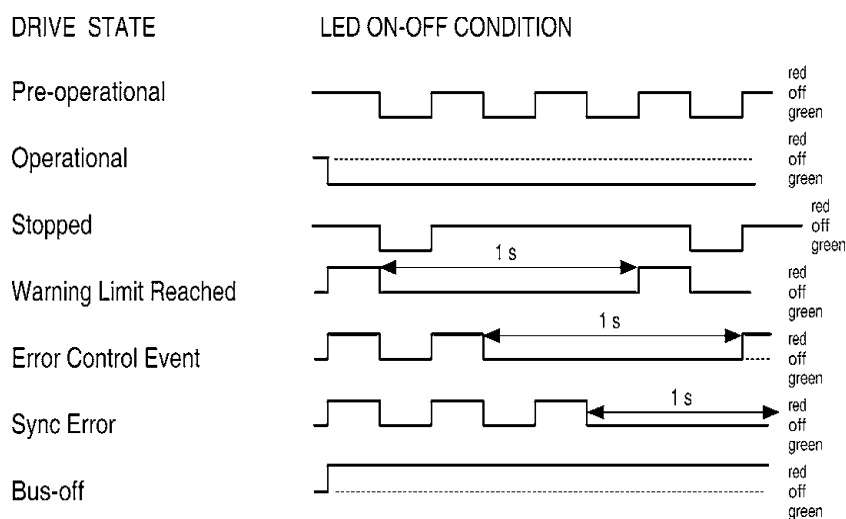
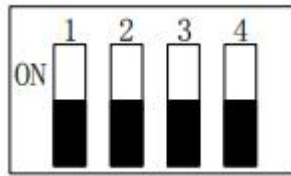

Figure 3.2 CAN communication indicators

3.3 ADDR S1 DIP switch

The switch is used to dial the driver communication station number, and the switch is dialed according to the BCD code encoding mode



S1 indicates the station number of the DIP switch

S1 switch Number	Corresponding station number
1	1
2	2
3	4
4	8

For example, to set the station number to 3, S1 switch 1,2 to ON, other OFF, $1+2=3$; If you want to set the station number to 12, switch S1 3,4 to ON, and the others to OFF, $4+8=12$

3.4 Serial communication terminal J6

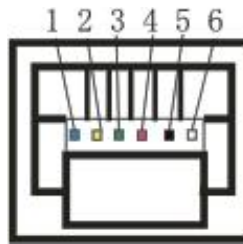
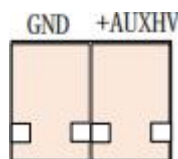

Figure 3.6 RJ11 6-pin crystal head holder

pin	definition	function
2	RXD	RS232 communication receiver
3	GND	Communication power grounding
5	TXD	RS232 communication sender

3.5 Auxiliary power supply J7

If there is a driver with J7 socket, this is the auxiliary power port. If necessary, you can connect it. If connected, +HV is disconnected from power and +AUXHV is powered on, but there is no action when issuing commands



GND	0V
+AUXHV	+24V (or \leq mains voltage)

4. Control port hardware description

4.1 RS-232 Communications (RXD, TXD, GND)

The serial ports are full-duplex and three-wire (RXD, TXD, GND)RS-232, with a baud rate from 9600 to 115200. The wiring terminal is J6 through the debugging software or serial port debugging tool. The debugging cables are shown as follows

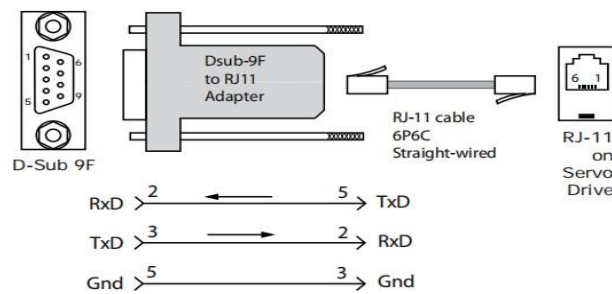

4.2 CAN bus (CANH,CANL,GND) and RS485 wiring

CAN bus is based on CAN V2.0B physical layer. The signals of CAN physical layer include CANH, CANL and GND, and communicate with CANopen protocol. Electrical interface uses TJA1051 high speed transceiver. The physical address of the drive CAN communication ranges from 0 to 127. The default address is 0. You can change the rS-232 communication port address, reset or restart the drive to take effect. Through the CAN communication interface, a very effective combination of high data rate and low cost multi-axis motion control system CAN be realized. The wiring terminal is J4 and J5. The RS485 bus connection is the same as that of CAN.

CAN network CAN be connected as shown below:

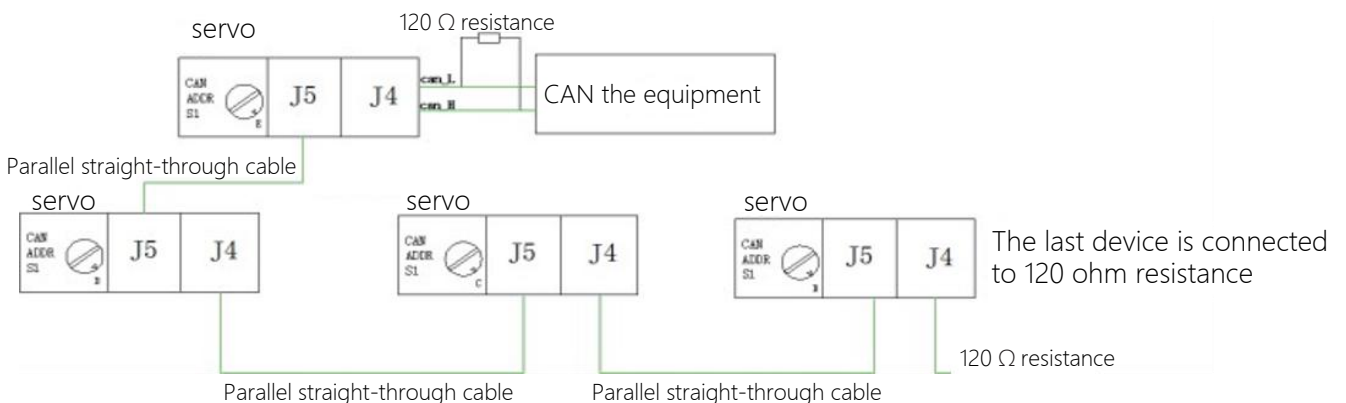

Note: The total resistance on the CAN network is 60 ohms. If the first driver on the CAN device has a resistance, no resistance is required

4.3 Analog signal input (Ref+,Ref-)

± 10 Vdc differential analog input, maximum input voltage ± 10 Vdc, input impedance about 5.36K, resolution 12 bits. The analog signal can be used for torque, speed and position control.

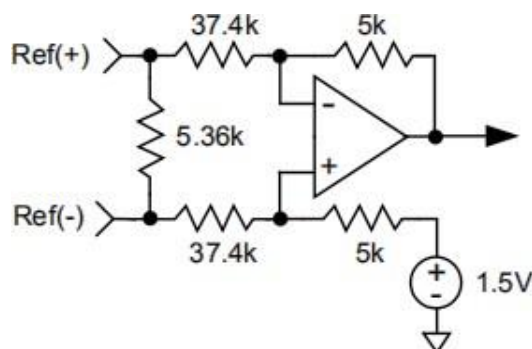

Figure 4.3.1 Analog hardware input circuit



Figure 4.3.2 Analog input wiring of external power supply

4.4 Digital input signal

BC Series brushless has 4 digital input ports, 3 have programmable function, drive power PWM output and security enable fixed by IN1 control, through this port can achieve power circuit hardware cut off.

According to the port function of controller and RC filtering time of hardware, the input signal port can be divided into universal input port and high-speed input port, and the function of each port can be changed programmatically.

4.4.1 Universal input signal terminal (IN1、IN2)

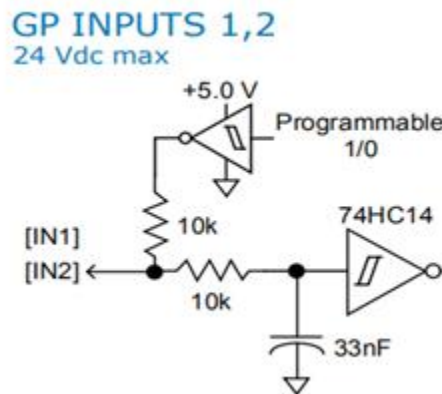

Figure 4.4.1 IN 1-2 hardware input circuit

IN1, IN2, are universal input signal terminals, and the control logic and function can be set by programming. IN1 is fixed for the driver's enable control, which takes effect through the software parameter setting high/low level.

4.4.2 High speed input signal terminals (IN3、IN4)

IN3 and IN4 are high-speed input terminals that can be used as PWM inputs

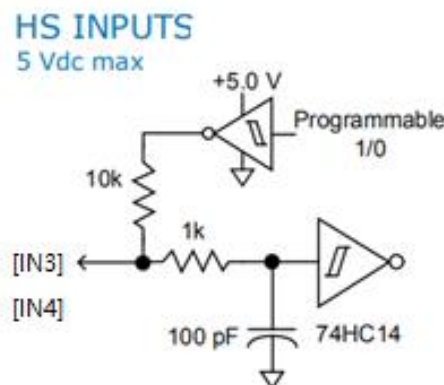

Figure 4.4.3 IN3, IN4 internal hardware diagram

4.5 Digital output signal

BC series driver has 2 digital outputs, the digital output IO port uses MOSFET open output, and the internal diode is pulled up to 5V through 1k resistance in series. The port can withstand voltage up to 24VBC and the current can withstand up to 300mADC. The output function of the port can be changed according to internal programming.

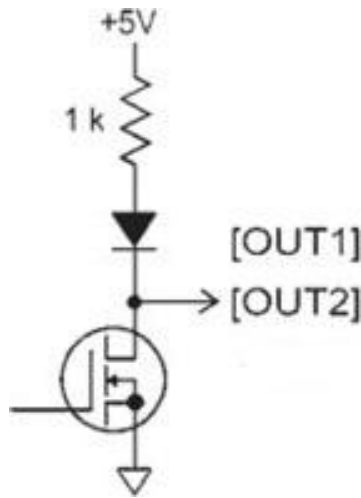

Figure 4.5.1 Digital output hardware circuit

4.5.1 PWM signal input

4.5.2 Single-ended PWM duty cycle = 0~100% pulse control

The motor speed and torque can be controlled by PWM signal, including single-end PWM duty cycle + direction signal

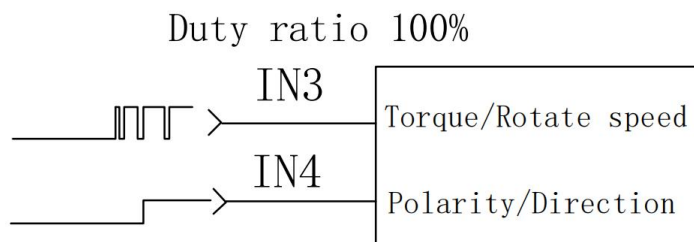

Figure 4.5.2 100% duty cycle + direction control

4.5.3 motor locks the brake

The digital output ports OUT1, OUT2 and OUT3 can all be set as motor lock brake control. In the case of no fault and motor enabling, the brake is energized and the brake is released. In the case of any fault, the brake power is quickly disconnected to stop the motor. Since the motor brake is a perceptual device, the reverse current return diode must be connected in parallel.

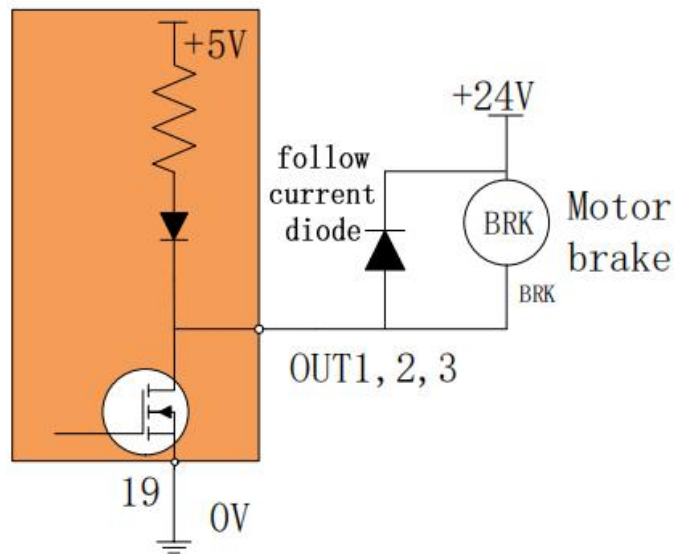
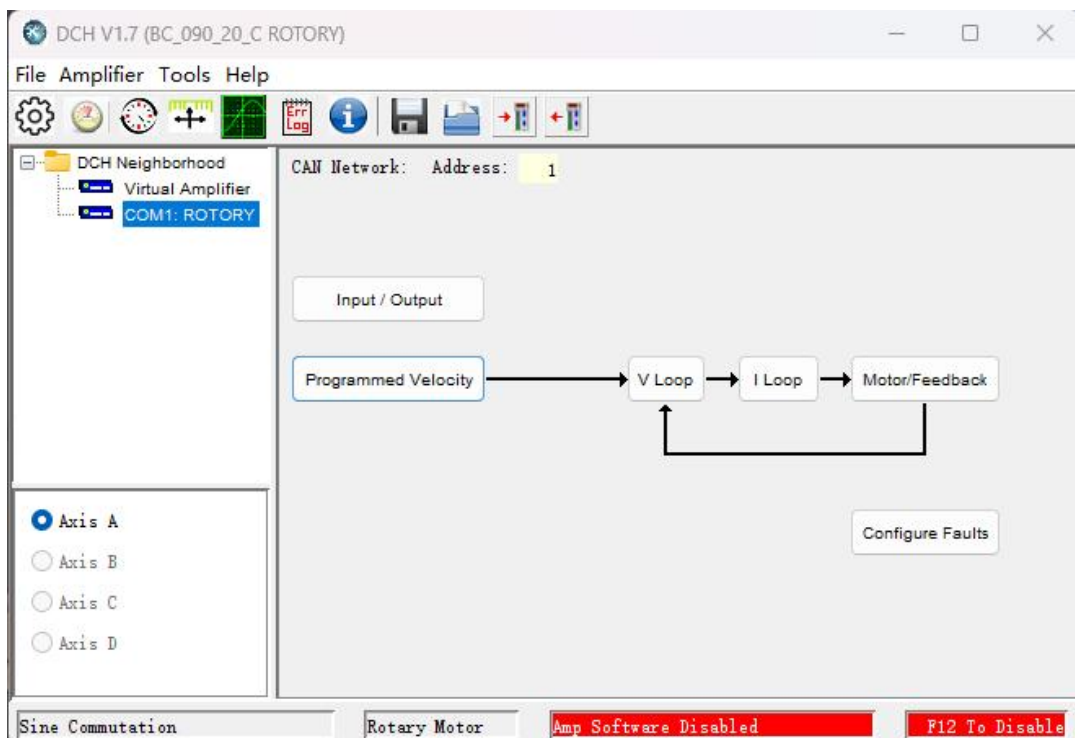

Figure 4.5.3 External circuit of motor brake

5 Driver parameter setting

BC series drive can be through RS232 serial port, through DCH tuning software can set parameters, monitor motor status, collect data waveform, etc. Complete system debugging quickly and intuitively. For details, see the debugging software instructions.



6、 BC brushless system wiring diagram

6.1 Typical wiring diagram

BC Series drive Typical connection

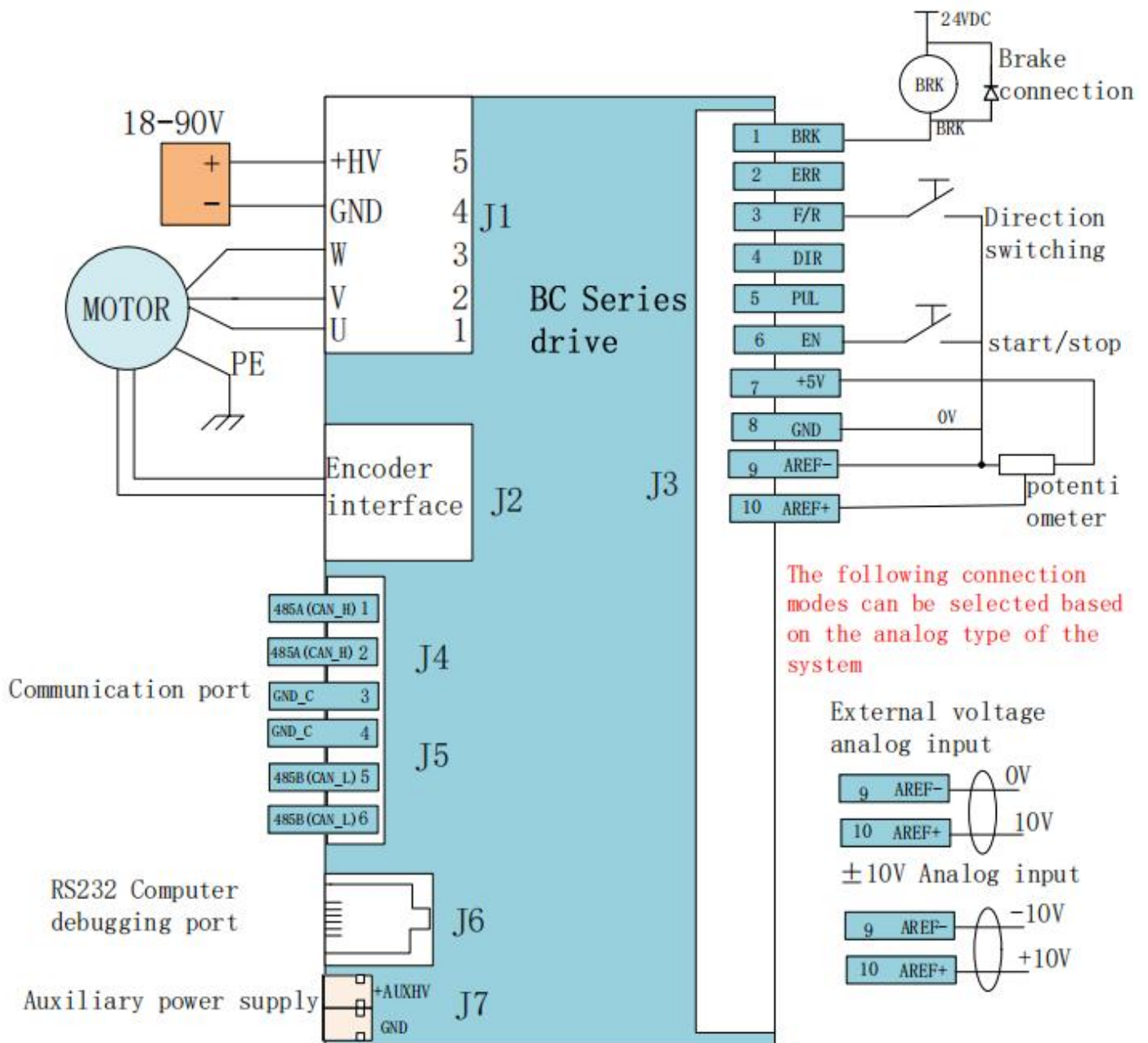

Contact Us

Shenzhen ONKE Technology Co.

Tel: 0755-27387873 27381841

Email: onke@sz-onk.com

Address: Block 13, Huaide Cuihu Industrial Park, Fuhai Street,
Baoan District, China

Revision record

Date	Version number	Revised content	
		Modify location	Modify content
20241226	V0.1	/	New edition