

DH series servo driver operating manual

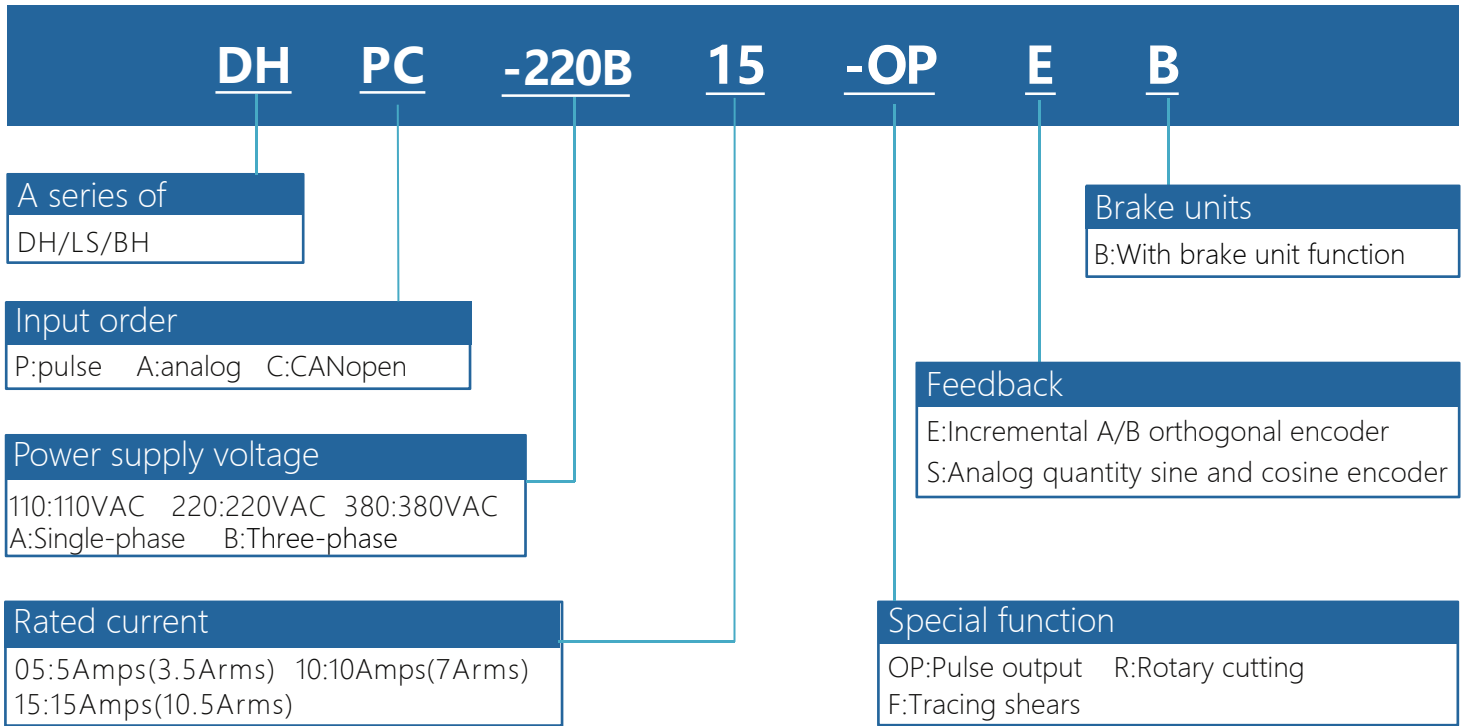

DH Series servo driver model description



Attention to:

1.The driver supply voltage must be greater than or equal to the rated voltage of the motor

2.The rated current of the driver must be greater than or equal to the rated current of the motor

DH Series driver specifications summary table

Driver model	Service voltage	Rated current Amps(Arms)	Peak current Amps(Arms)6S	Feedback type	Overall dimensions	Weight
DHPC-380B05-OPEB	380VAC (250~440VAC)	5A(3.5A)	15A(10.5A)	Incremental	204*140*60mm	1.2kg
DHPC-380B10-OPEB		10A(7A)	30A(21A)			
DHPC-380B15-OPEB		15A(10A)	37.5A(26.5A)			
DHPC-380B20-OPEB		20A(14A)	60A(42A)		285*188*114mm	3.8KG
DHPC-380B25-OPEB		25A(17A)	62.5A(44A)			
DHPC-380B30-OPEB		30A(21A)	70A(49A)			
DHPC-380B35-OPEB		35A(24.5A)	70A(49A)			
DHPC-380B50-OPEB		50A(35A)	80A(56A)			

DH Serial terminal Definition

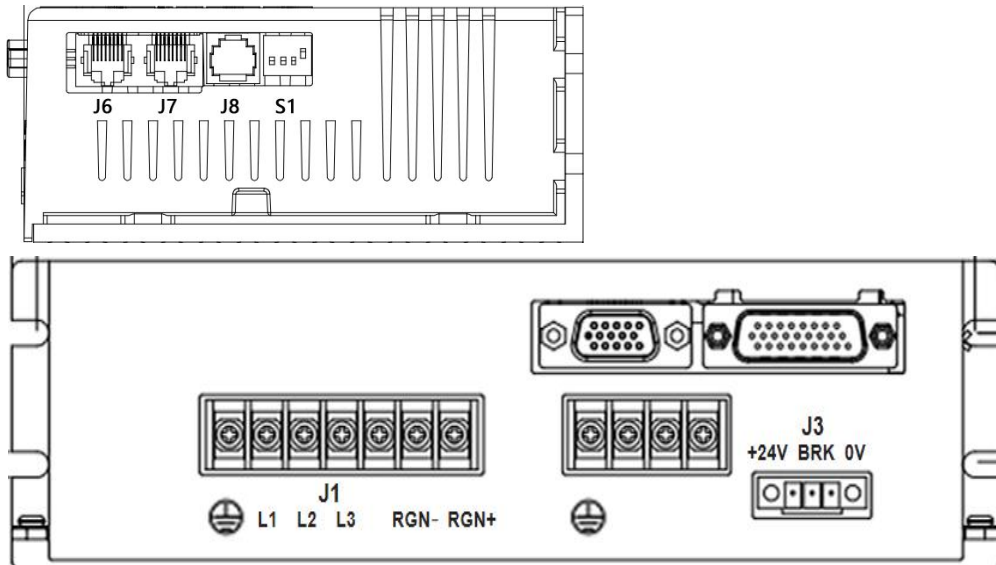

DH Series outline dimension drawing

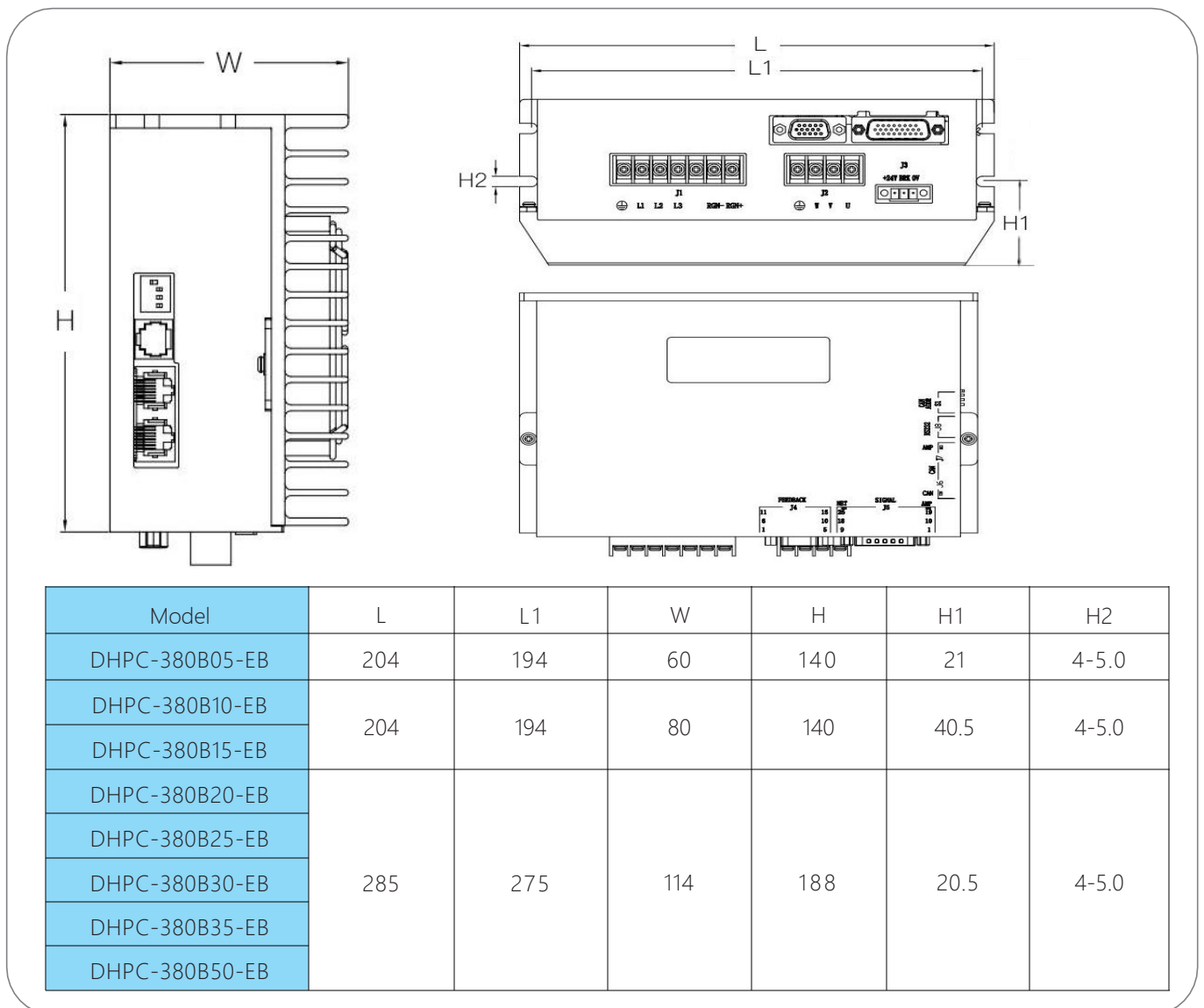

1、 Product introduction:

1. An overview of the

DH series programmable intelligent servo driver is a universal, high performance, AC/DC power supply, compact structure of all digital servo driver. Mainly used in linear (DDL), torque (DDR), voice coil, brushless servo motor position, speed, torque control system. It can be operated in three modes of independently programmable control (STANDalone), external control or distributed network control, and can support incremental encoder, analog sine and cosine encoder(1.0Vp-p), rotary transformer (Resolver) and digital Hall feedback.

2. Technical characteristics

- ◆Control mode: position, speed, torque;
- ◆Motion mode: electronic gear, electronic CAM, proportional linkage, point to point;
- ◆Programmable protection: position error, over current, over voltage or under voltage, I²t, output short circuit overload and other multi-directional protection;
- ◆Type of driving motor: brushless motor, brush motor, linear motor, voice coil motor, etc;
- ◆Position feedback: incremental encoder, Hall, grating ruler, analog sine and cosine (Sin/Cos) encoder(1.0Vp-p), rotary transformer (external conversion card);
- ◆Pulse response frequency up to 2MHz, with digital filtering function;
- ◆RS232 serial interface, baud rate up to 115KB;
- ◆CAN2.0 local area bus, compatible with CANopen DS-402, baud rate up to 1MHz ;
- ◆Power supply voltage: AC380V ;

Input voltage	250~440VAC	Single-phase, three-phase
Input frequency	47-63Hz	

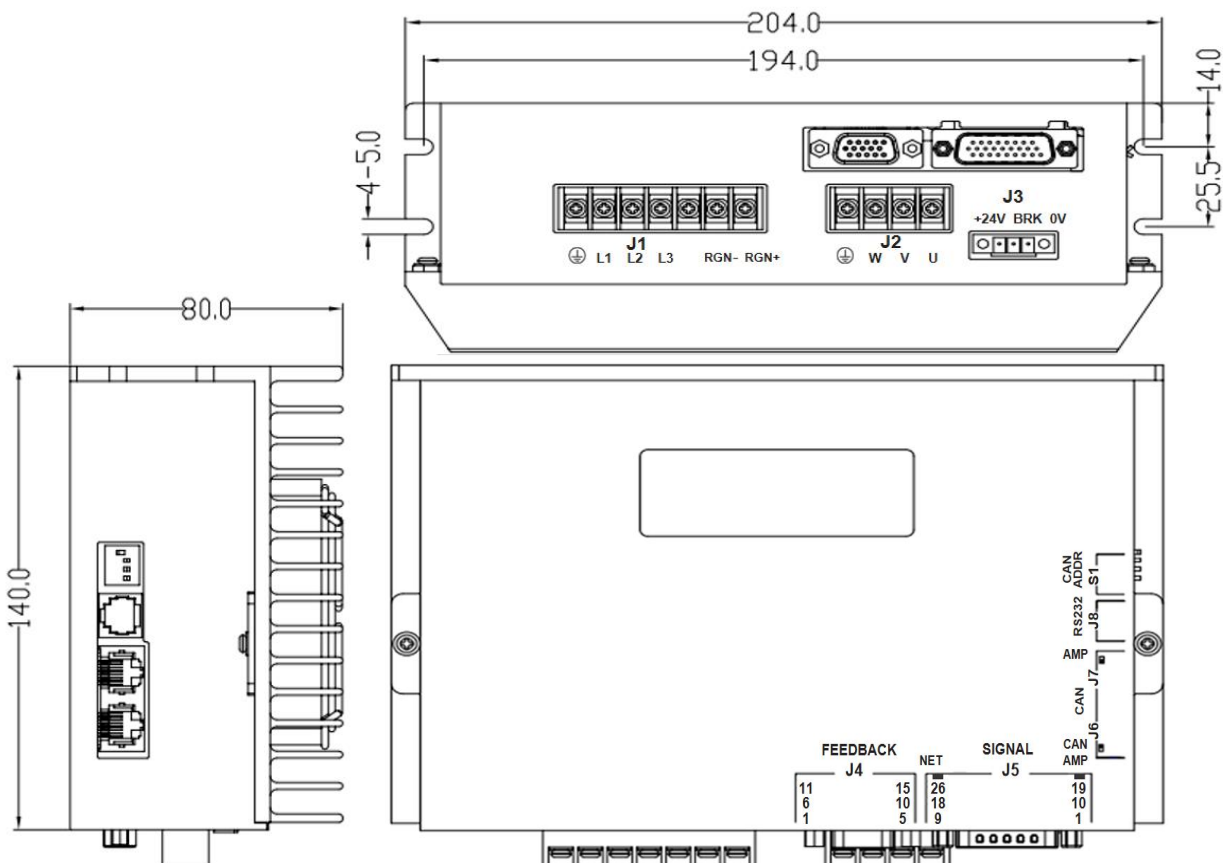

1.3 Electrical specifications for servo drivers

Position control	Command control mode			Pulse, $\pm 10V$ analogue input, CANopen, function generator Trace indexing, software programming
	Input signal	Pulse instruction	Input pulse pattern	The command can be direction + pulse, ORTHOGONAL pulse of A and B phases, and CW/CCW pulse.
			Signal format	Differential input, open collector
			Maximum pulse frequency	Differential input :(Max. 2Mpps) Open collector :(Max. 500Kpps)
	Simulation instruction	Voltage range	impedance	Differential input impedance =5K Ω
Speed control	Command control mode			PWM, $\pm 10V$ analog, function generator, software programming
	Input signal	PWM	polarity	PWM=0 \sim 100%, polarity=1/0
			nonpolar	PWM=50% +/-50%
			Frequency range	Minimum 1kHz, maximum 100kHz
			Minimum pulse width	220ns
	Simulation instruction	Voltage range	impedance	Differential input impedance =5K Ω
Current control	Command control mode			PWM, $\pm 10V$ analog, function generator, software programming
	Input signal	PWM	polarity	PWM=0 \sim 100%, polarity=1/0
			nonpolar	PWM=50% +/-50%
			Frequency range	Minimum 1kHz, maximum 100kHz
			Minimum pulse width	220ns
	Simulation instruction	Voltage range	impedance	Differential input impedance =5K Ω
I/O signal	Digital input IN		Number of Ports	12(IN6, IN7, IN8, IN9 and IN10 are high-speed ports, IN5 is used for motor temperature protection)
			Signal format	NPN(low active)
			Settable function	Servo enable, external reset, positive/reverse limit, motor running stop, high-speed analog acquisition control, PWM synchronous signal input, high-speed pulse input, etc
	Digital output OUT		Number of Ports	3
			Signal format	NPN(low effective), can withstand a maximum current of 300mAdc, maximum voltage of 30Vdc
			Settable function	Fault signal, brake control, PWM sync signal, custom event track state, position trigger, program control

Function	LED indicator			Status indicator, CAN network indicator
	Communications functions	RS-232	Baud rate	9600-115200
			agreement	Full duplex mode, ASCII or binary format
		CAN	Baud rate	20kbit/s-1Mbit/s
			agreement	Canopen application layer DS-301V4.02
			equipment	Dsp-402 device driver and motion control
Protection function				Overvoltage, overcurrent, undervoltage, overload, overheating, abnormal encoder, too large position tracking error and other protection
Using environment	Installation location			Non-corrosive gas, flammable gas, etc
	Altitude			Below 1000 m
	Temperature			0°C~+50°C
	Humidity			5%~95%RH, No condensation of water droplets
	Resistance to vibration/impact			Less than 4.9m/s ² / less than 19.6m/s ²

2、 Definition of wiring port

2.1 Mains three-phase input terminal J1

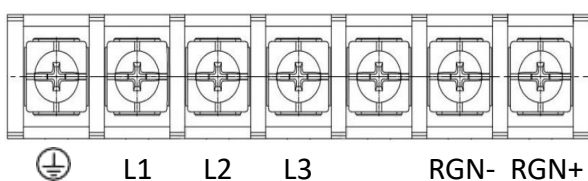

Figure 2.1 Fence terminal socket

L1	AC380V
L2	
L3	
⊕	GND
RGN-	Brake Resistor Interface
RGN+	

2.2 Motor connector J2

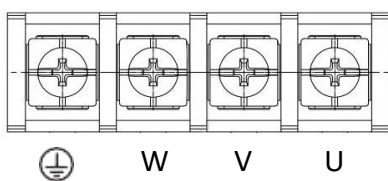

Figure 2.2 Fence terminal socket

U	Motor cable U
V	Motor cable V
W	Motor cable W
⊕	Motor cable PE

2.3 External 24VDC input terminal J3

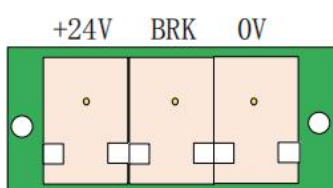

Figure 2.3 European Standard Terminal Sockets

+24VDC	External input \geq 50W
BRK	Connect the motor holding wire
0V	0V

2.4 Motor encoder input J4

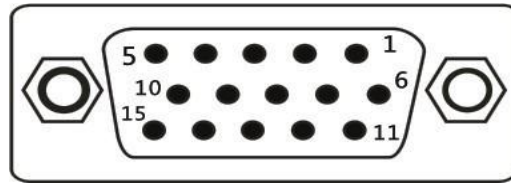

Figure 2.4 three rows of DB15 female seats

pin	define	function	pin	define	function
1	A+	Motor encoder A+input	9	V+	Motor encoder V+ input
2	A-	Motor encoder A- input	10	COS+	COS+
3	B+	Motor encoder B+input	11	W+	Motor encoder W+ input
4	B-	Motor encoder B- input	12	SIN-	SIN-
5	Z+	Motor encoder Z+input	13	+5V	Motor signal line +5V
6	Z-	Motor encoder Z- input	14	0V	Motor signal cable GND
7	U+	Motor encoder U+input	15	COS-	COS-
8	SIN+	SIN+			

2.5 Control signal I/O terminal J5

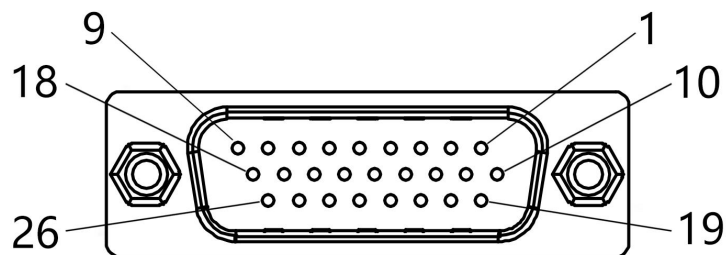

Figure 2.5 Three rows of DB26 male connector

pin	define	function	pin	define	function
1	FG	grounding	14	OUT2	custom
2	IN5	Motor temperature	15	OUT3	custom
3	IN1	Enable	16	EONA+	Motor encoder output signal A+
4	IN2	custom	17	EONA-	Motor encoder output signal A-
5	IN3	custom	18	EONB+	Motor encoder output signal B+
6	IN4	custom	19	EONB-	Motor encoder output signal B-
7	IN6	custom	20	EONZ+	Motor encoder output signal Z+
8	IN7	custom	21	EONZ-	Motor encoder output signal Z-
9	IN8	custom	22	+5V	5V power output(400mA)
10	IN9	custom	23	GND	power ground
11	IN10	custom	24	Ref+	Analog quantity + input
12	IN11	custom	25	Ref-	Analog quantity - input
13	OUT1	custom	26	IN12	custom

2.6 CAN communication terminal J6&J7

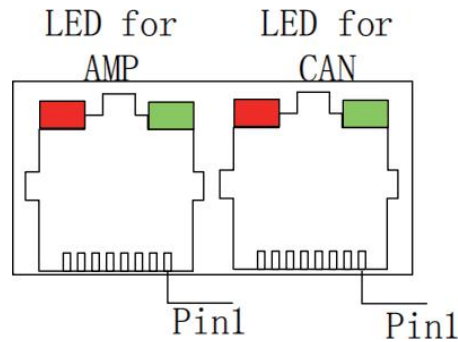

Figure 2.6 RJ45 8-pin crystal socket

pin	definition	function
1	CANH	CANH signal
2	CANL	CANL signal
3/7	GND	Communication power grounding

Note: The two RJ45 ports in J6/J7 are defined in the same way to facilitate bridging during communication.

2.7 Definition of indicator Status

2.7.1 Drive status indicator (AMP)

Red/green leds tell us the status of the drive by changing color and blinking or not. Possible scenarios include:

Green/no flash	drive is OK and enabled
Green/Slow blinking	drive is OK but not enabled. After enabled, it can run
Green/Flash	Positive limit switch or negative limit switch is effective, the motor will only move in the direction not prohibited by the limit switch
Red/Fixed	Instantaneous failure, after troubleshooting amplifier restart operation
Red/flashing	Lock the fault and restart the amplifier to resume operation

2.7.2 CAN Communication indicator (CAN)

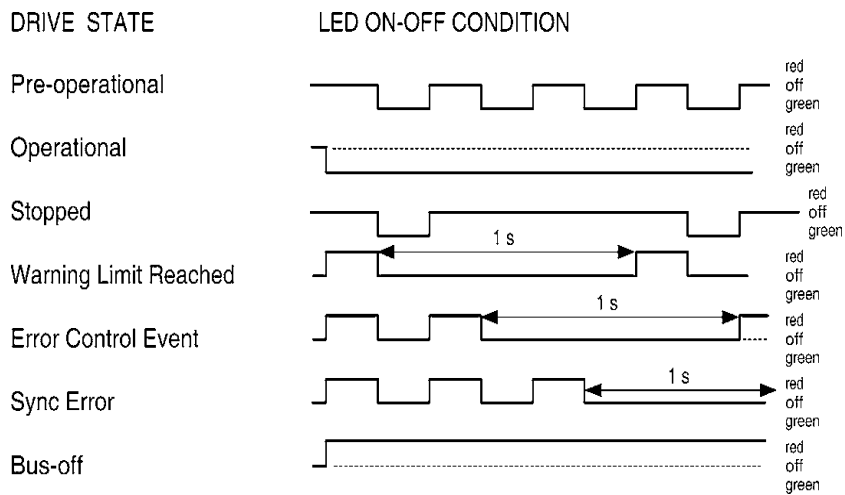

2.8 Serial communication terminal J8

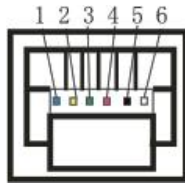
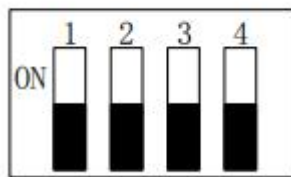

Figure 2.8 RJ11 6-pin crystal head holder

pin	definition	function
2	RXD	RS232 communication receiver
3	GND	Communication power grounding
5	TXD	RS232 communication sender

2.9 SW Driver CAN address DIP switch

When the external DIP switch is selected for software Settings, the dip switch is effective. The switch encoding is in the BCD code sequence, and takes effect when the dip switch is switched to ON.



SW Indicates the station number of the DIP switch

SW switch Number	Corresponding stand No.
1	1
2	2
3	4
4	8

For example, if you want to set the station number to 3, switch the SW switch 1, 2 to ON and the other switch to OFF, $1+2=3$; If you want to set the station number to 12, dial SW 3,4 to ON, other to ooff, $4+8=12$

3、 Control port hardware description

3.1 RS-232 Communications (RXD, TXD, GND)

The serial ports are full-duplex and three-wire (RXD, TXD, GND)RS-232, with a baud rate from 9600 to 115200. The wiring terminal is J6 through the debugging software or serial port debugging tool. The debugging cables are shown as follows

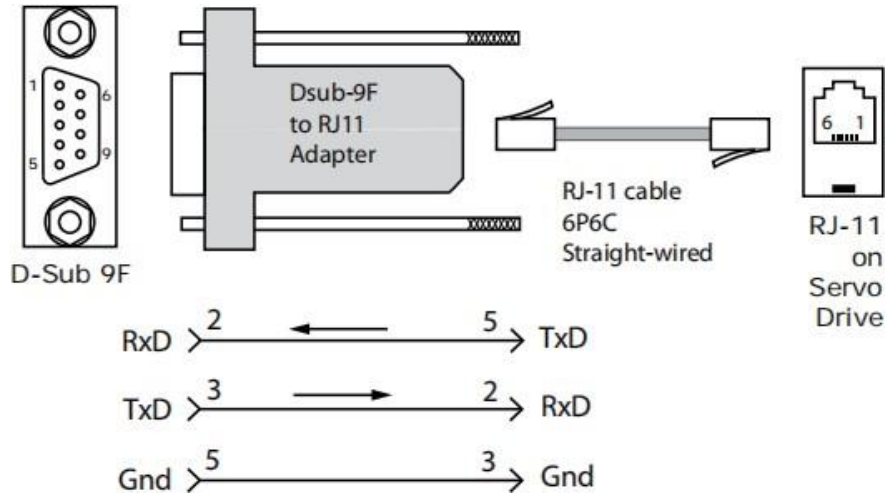

3.2 CAN bus (CANH, CANL, GND)

CAN bus is based on CAN V2.0B physical layer. The signals of CAN physical layer include CANH, CANL and GND, and communicate with CANOpen protocol. Electrical interface uses TJA1051 high speed transceiver. The physical address of the drive CAN communication ranges from 0 to 127. The default address is 0. You can change the rS-232 communication port address, reset or restart the drive to take effect. Through the CAN communication interface, a very effective combination of high data rate and low cost multi-axis motion control system CAN be realized. The wiring terminal is J6/J7.

CAN network CAN be connected as shown below:

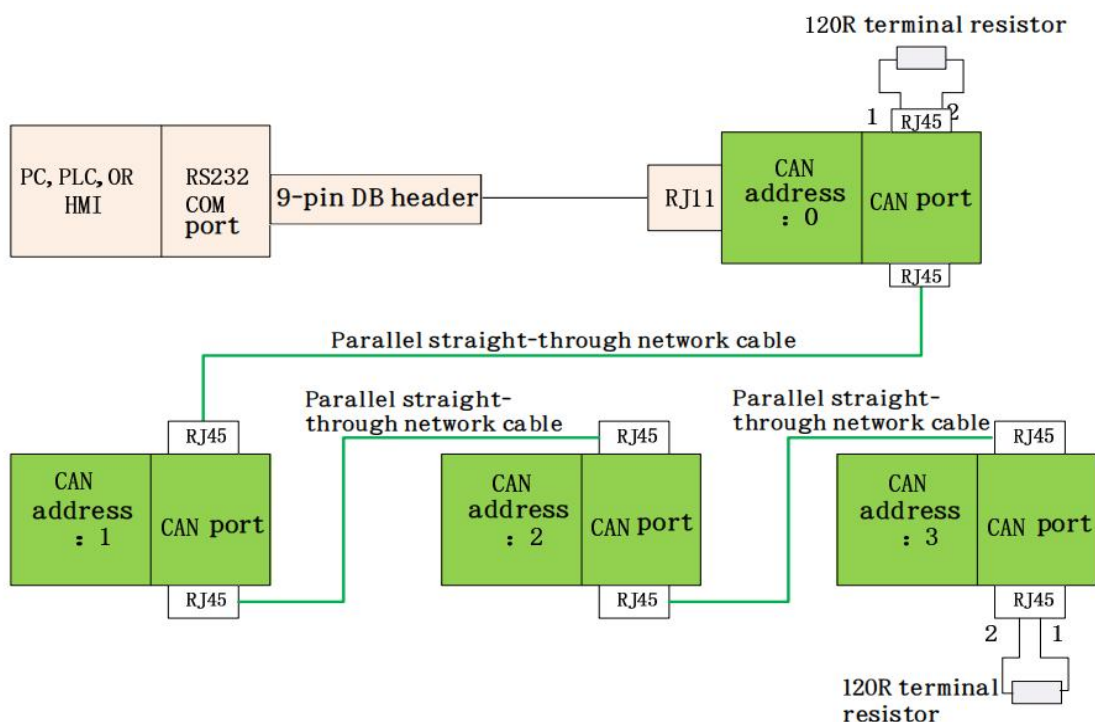

3.3 Analog signal input(Ref+,Ref-)

$\pm 10\text{Vdc}$ differential analog input, maximum input voltage $\pm 10\text{Vdc}$, input impedance about 5.36K , resolution 12 bits. The analog signal can be used for torque, speed and position control.

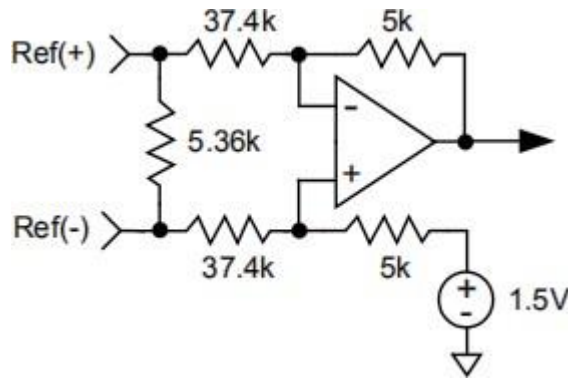

Figure 3.3.1 Analog hardware input circuit

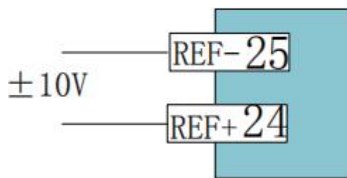

Figure 3.3.2 Analog input wiring of external power supply

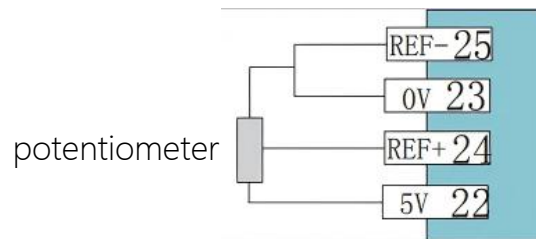

Figure 3.3.3 Analog input wiring of internal power supply

3.4 Digital input signal

DH series servo has 12 digital input ports, 11 have programmable function, drive power PWM output and security enable fixed by IN1 control, through this port can achieve power circuit hardware cut off.

According to the port function of controller and RC filtering time of hardware, the input signal port can be divided into universal input port and high-speed input port, and the function of each port can be changed programmatically.

3.4.1 Universal input signal terminal(IN1、IN2、IN3、IN4、IN5)

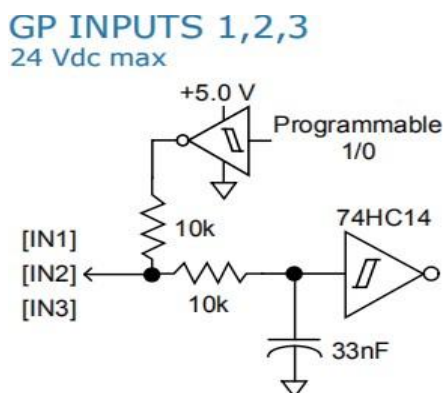

Figure 3.4.1 IN1-IN3 hardware input circuit

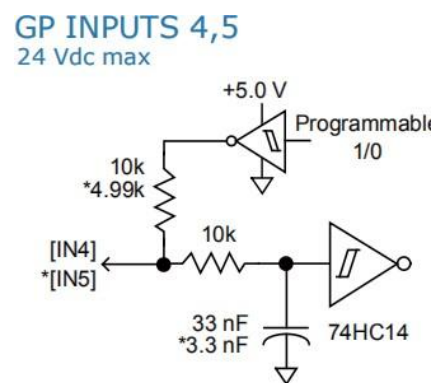

Figure 3.4.2 IN4-IN5 hardware input circuit

IN1, IN2, IN3, IN4, and IN5 are universal input signal terminals. The control logic and function can be set programmatically. IN1 is fixed for driver enable control, IN5 is mainly used for motor temperature protection input, through the software parameter setting high/low level takes effect.

3.4.2 High speed input signal terminal (IN6、IN7、IN8、IN9、IN10)

IN6, IN7, IN8, IN9, IN10 are high-speed input terminals. In addition to being used as general terminals, they can also be used as high speed pulse input. The pulse input port is fixed as (IN9, IN10).

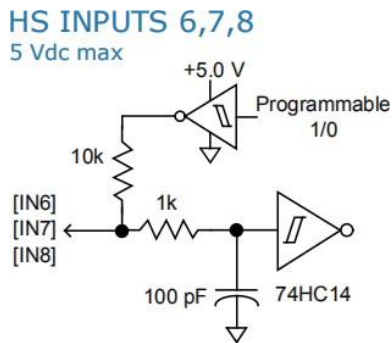

Figure 3.4.3 IN6,7,8 internal hardware diagram

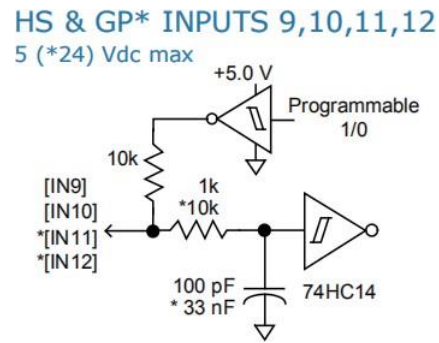

Figure 3.4.4 IN9,10,11,12 internal hardware diagram

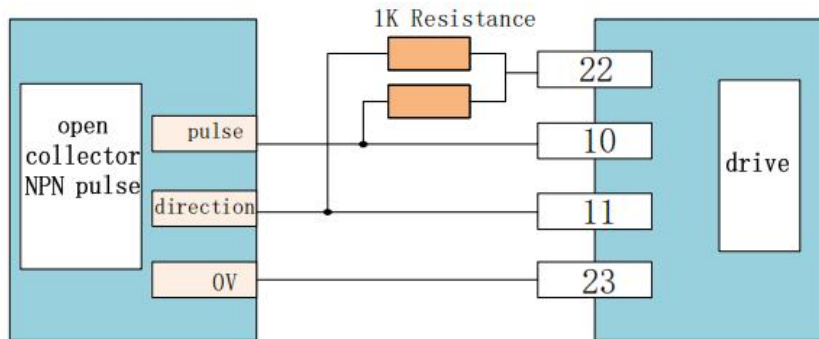

Figure 3.4.5 Open-collector NPN pulse input diagram

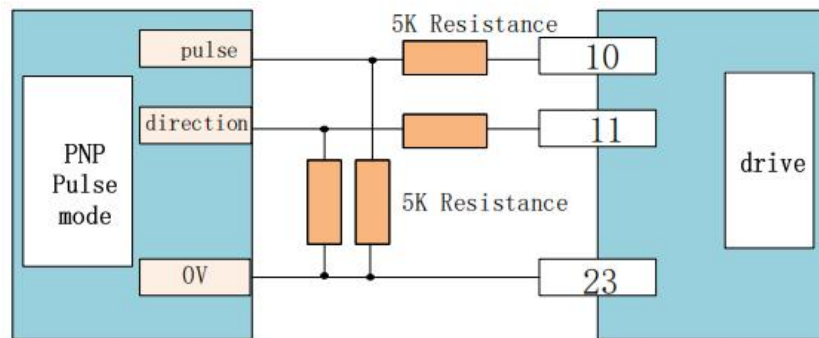

Figure 3.4.6 PNP pulse input diagram

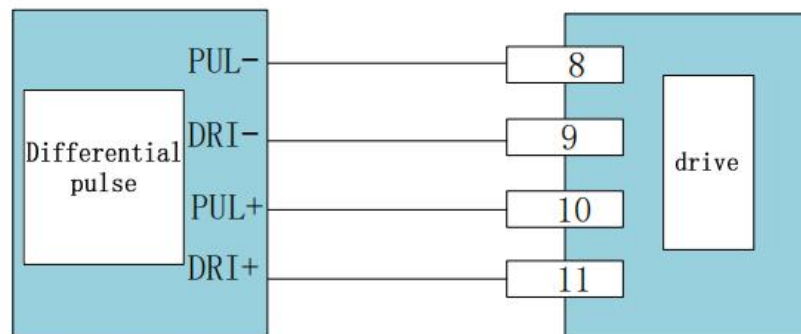

Figure 3.4.7 Differential Pulse Input Diagram

3.5 Digital output signal

DH series drivers have three digital output ports, digital output IO port MOSFET open output, internal through diode series 1K resistance to pull up to 5V, the port can withstand voltage to 24Vdc, the maximum current can withstand 300mAdc. The output function of the port can be changed according to internal programming.

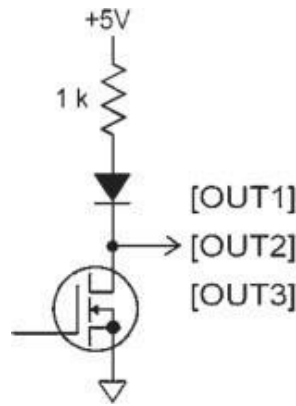

Figure 3.5 Digital output hardware circuit

3.6 PWM signal input

The motor can be controlled by PWM signal for speed and torque, including single-end PWM duty ratio + direction signal and single-end PWM duty ratio $\pm 50\%$ modulation.

3.6.1 Single PWM duty cycle = 0~100% pulse control

Duty cycle = 0 to 100%

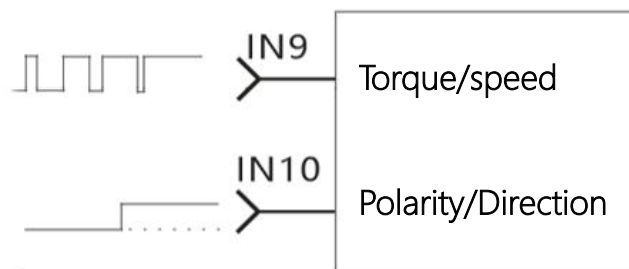

Figure 3.6.1 100% duty cycle + direction control

3.6.2 Single-end PWM duty cycle = 50%±50% pulse control

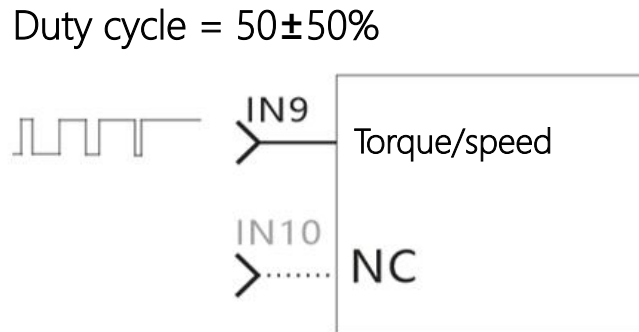

Figure 3.6.2 50%±50% duty cycle control

4、 Drive parameter Setting

DH series driver can set parameters, monitor motor state, collect data wave shape and so on through RS232 serial port. Complete system debugging quickly and intuitively. For details, see the instructions for Debugging Software.

5. System wiring diagram

Typical wiring diagram

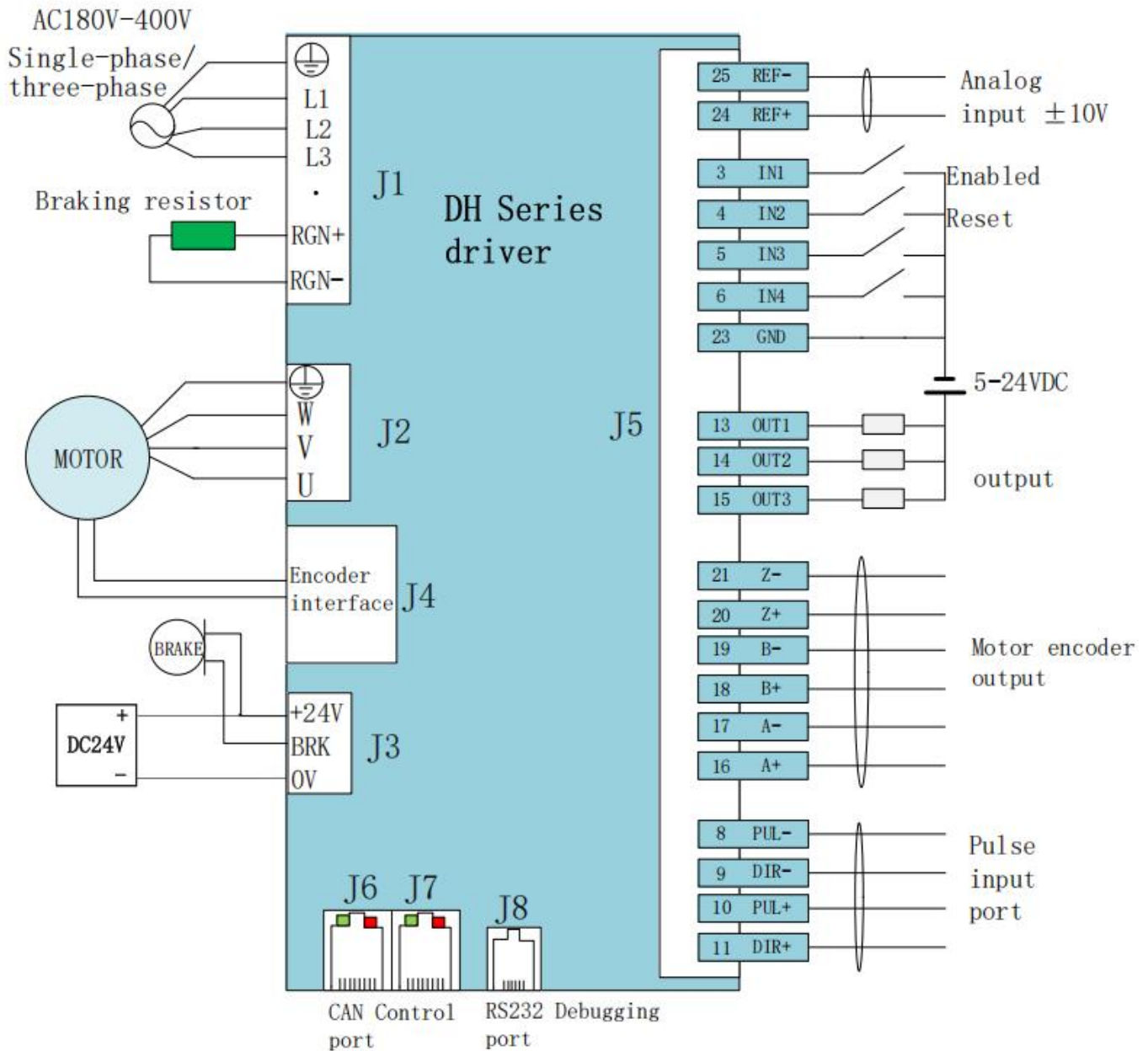

Description:

1. Input terminals IN1, IN2, IN3, IN4, IN5, IN 11, IN12 are common ports that can receive NPN and PNP signals. The maximum input voltage is 24V
2. IN6, IN7, IN8, IN9, IN10 are high-speed input ports with the highest input voltage of 5V

Contact Us

Shenzhen ONKE Technology Co.

Tel: 0755-27387873 27381841

Email: onke@sz-onk.com

Address: Block 13, Huaide Cuihu Industrial Park, Fuhai Street,
Baoan District, China

Revision record

Date	Version number	Revised content	
		Modify location	Modify content
20241228	V0.1	/	New edition