

BL series servo driver operating manual

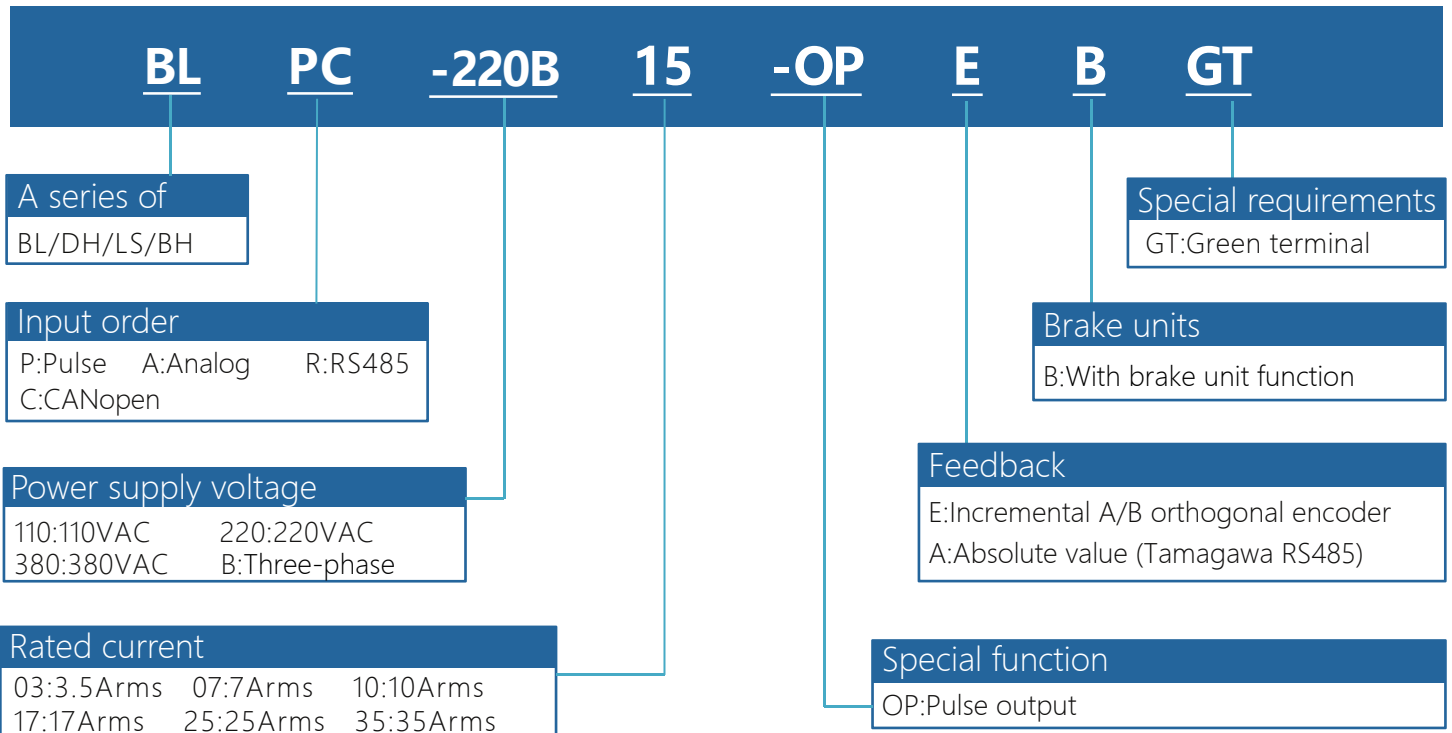

BL Series servo driver model description



Attention to:

1.The driver supply voltage must be greater than or equal to the rated voltage of the motor

2.The rated current of the driver must be greater than or equal to the rated current of the motor

BL Series driver specifications summary table

Driver model	Service voltage	Rated current Arms	Peak current Arms pk10S	Feedback type	Overall dimensions	Weight
BLPC/R-110B07-OPE/AB	110VAC (60~155VAC)	7A	14A	Incremental Absolute value	194*113.5*58mm	0.9KG
BLPC/R-110B10-OPE/AB		10A	26.5A		204*140*60mm	1.2KG
BLPC/R-110B14-OPE/AB		14A	42A		204*140*80mm	1.9KG
BLPC/R-110B25-OPE/AB		24.5A	73.5A		285*188*114mm	3.8KG
BLPC/R-110B35-OPE/AB		35A	84A			
BLPC/R-220B03-OPE/AB	220VAC (150~240VAC)	3.5A	10.5A		194*113.5*58mm	0.9KG
BLPC/R-220B07-OPE/AB		7A	14A		204*140*60mm	1.2KG
BLPC/R-220B10-OPE/AB		10A	26.5A		204*140*80mm	1.9KG
BLPC/R-220B14-OPE/AB		14A	42A			
BLPC/R-220B17-OPE/AB		17A	44A		285*188*114mm	3.8KG
BLPC/R-220B25-OPE/AB		24.5A	73.5A			
BLPC/R-220B35-OPE/AB		35A	84A			

BL Serial terminal Definition

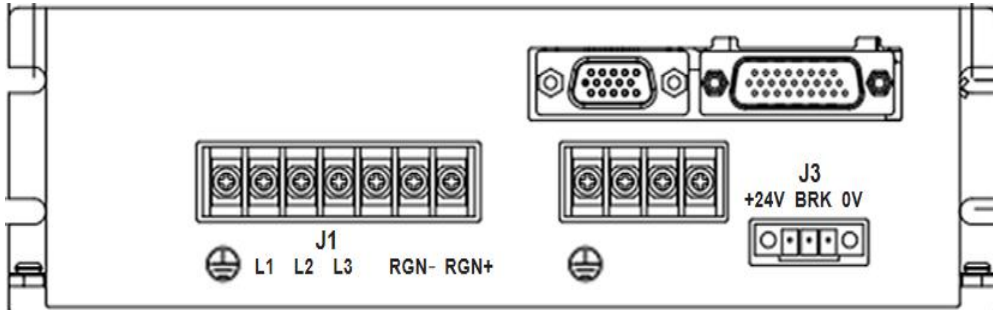
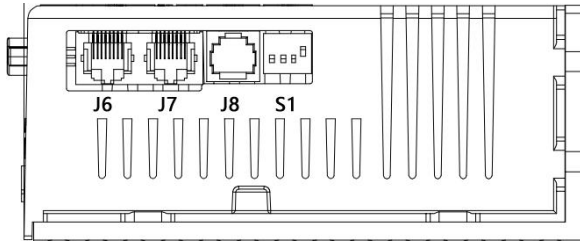

BL Series outline dimension drawing

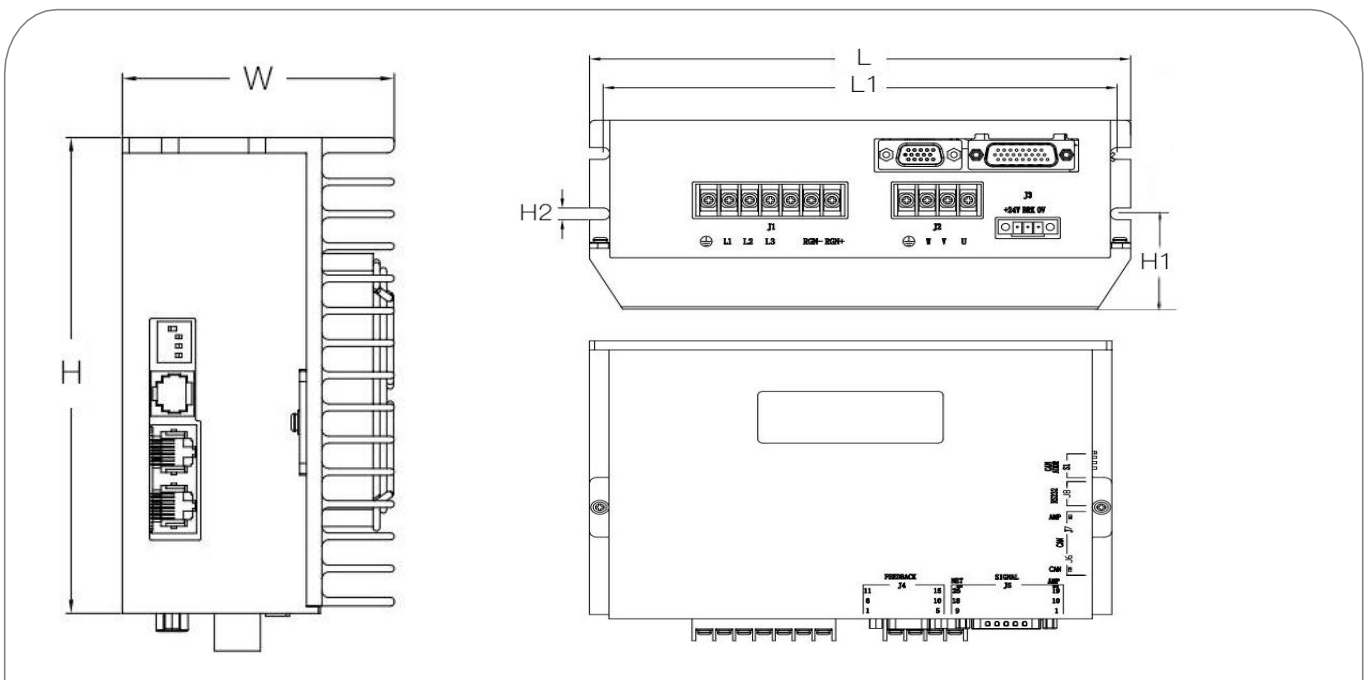

Model	L	L1	W	H	H1	H2
BLPC/R-110B07-OPE/AB	194	183.8	58.5	113.5	21	4-5.0
BLPC/R-110B10-OPE/AB	204	194	60	140	21	4-5.0
BLPC/R-110B14-OPE/AB	204	194	80	140	21	4-5.0
BLPC/R-110B25-OPE/AB	285	275	114	188	20.5	4-5.0
BLPC/R-110B35-OPE/AB	285	275	114	188	20.5	4-5.0
BLPC/R-220B03-OPE/AB	194	183.8	58.5	113.5	21	4-5.0
BLPC/R-220B07-OPE/AB	194	183.8	58.5	113.5	21	4-5.0
BLPC/R-220B10-OPE/AB	204	194	60	140	21	4-5.0
BLPC/R-220B14-OPE/AB	204	194	80	140	40.5	4-5.0
BLPC/R-220B17-OPE/AB	204	194	80	140	40.5	4-5.0
BLPC/R-220B25-OPE/AB	285	275	114	188	20.5	4-5.0
BLPC/R-220B35-OPE/AB	285	275	114	188	20.5	4-5.0

1、 Product introduction:

An overview of the

BL series programmable intelligent servo drive is a versatile, high-performance, AC/DC-powered, compact, fully digital servo drive. It is primarily used for position, speed, and torque control of brushless servo motors. It supports incremental encoders, resolvers, absolute encoders with the Tamagawa protocol, and digital Hall feedback.

2. Technical characteristics

- ◆Control mode: position, speed, torque;
- ◆Programmable protection: position error, over current, over voltage or under voltage, I^2t , output short circuit overload and other multi-directional protection;
- ◆Drive motor type: brushless motor, servo motor;
- ◆Position feedback: incremental encoder, digital Hall feedback; Absolute encoder Tamagawa protocol; rotary transformer (external conversion card).
- ◆Pulse response frequency up to 2MHz, with digital filtering function.
- ◆Communication mode: Only one RS485 or CAN can be selected;
 1. RS232 serial interface, baud rate up to 115KB;
 2. RS485 MODBUS RTU serial interface, baud rate up to 115KB;
 3. CAN communication, compatible with CANopen DS-402, baud rate up to 1MHz, Support PVT, zero return, interpolation.
- ◆Power supply voltage: AC110V/220V.

Input voltage	60~155VAC / 150~240VAC	Single-phase, three-phase
Input frequency	47-63Hz	

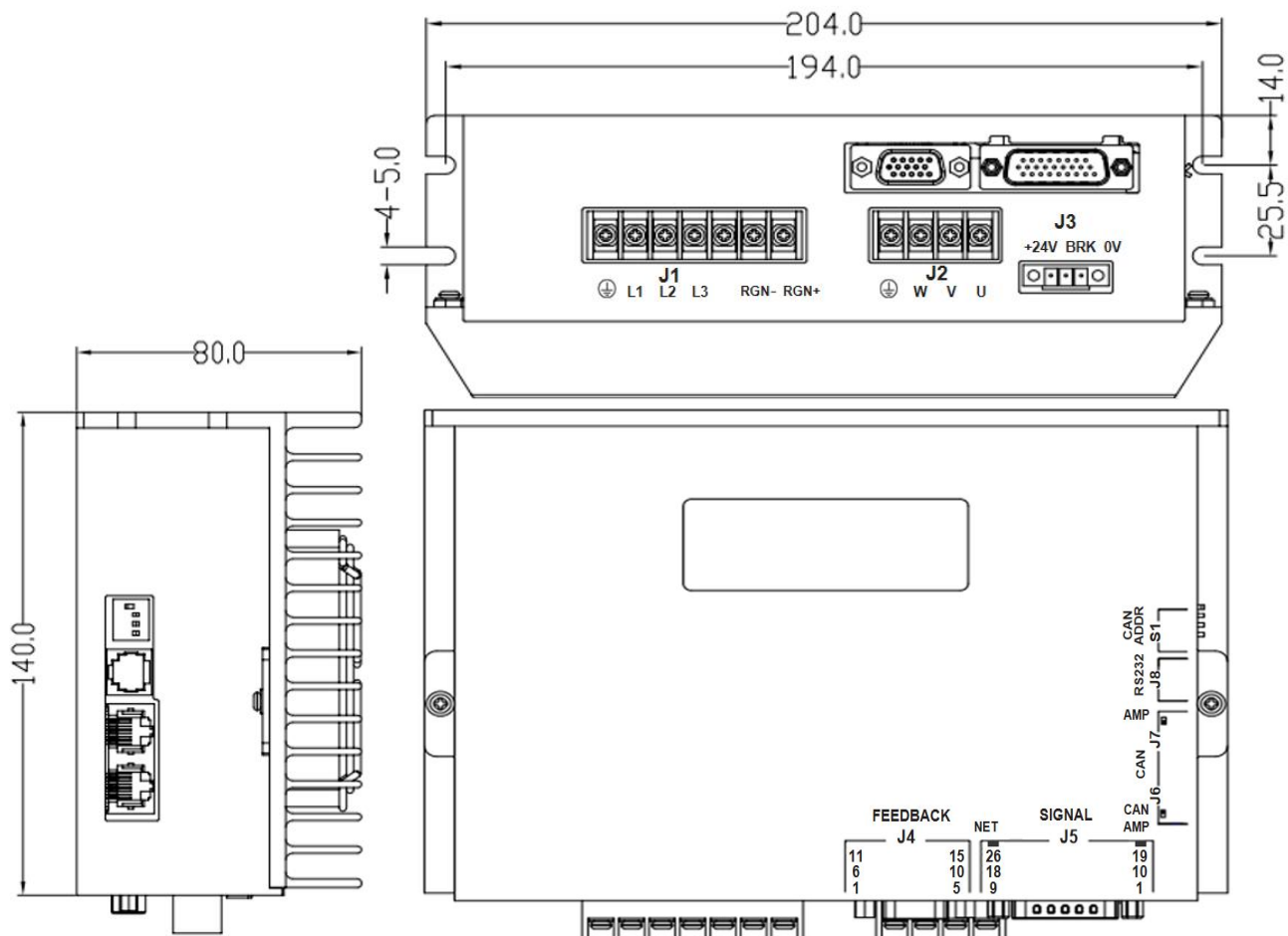

1.3 Electrical specifications for servo drivers

Position control	Command control mode			Pulse、 $\pm 10V$ analogue input、CANopen、RS485 MODBUS RTU
	Input signal	Pulse instruction	Input pulse pattern	Includes "direction + pulse", "A, B phase orthogonal pulse", "CW/CCW pulse" three command forms.
			Signal format	Open collector
			Maximum pulse frequency	Open collector: (Max. 500Kpps)
	Simulation instruction	Voltage range	Input voltage range $\pm 10V$	
Input impedance		Differential input impedance=5K Ω		
Speed control	Command control mode			PWM、 $\pm 10V$ analogue input、Pulse、CANopen、RS485 MODBUS RTU
	Input signal	PWM	Polarity	PWM=0 \sim 100%,polarity=1/0
			Nonpolar	PWM=50% +/-50%
			Frequency range	Minimum 1kHz, maximum 100kHz
			Minimum pulse width	220ns
	Simulation instruction	Voltage range	Input voltage range $\pm 10V$	
Input impedance		Differential input impedance=5K Ω		
Current control	Command control mode			PWM, $\pm 10V$ analogue input,CANopen,RS485 MODBUS RTU
	Input signal	PWM	Polarity	PWM=0 \sim 100%,polarity=1/0
			Nonpolar	PWM=50% +/-50%
			Frequency range	Minimum 1kHz, maximum 100kHz
			Minimum pulse width	220ns
	Simulation instruction	Voltage range	Input voltage range $\pm 10V$	
Input impedance		Differential input impedance=5K Ω		
I/O signal	Digital input IN		Number of Ports	12(IN6, IN7, IN8, IN9 and IN10 are high-speed ports, IN5 is used for motor temperature protection)
			Signal format	NPN(low level effective)
			Settable function	Servo enable, external reset, forward/reverse limit, motor stop, high-speed pulse input, etc.
	Digital output OUT		Number of Ports	3
			Signal format	NPN(low level effective),can withstand a maximum current of 300mA _{dc} , maximum voltage of 30V _{dc} .
			Settable function	Fault signals, brake control, custom event trajectory status.

Function	LED indicator		Status indicator, CAN network indicator	
	Communi- cations functions	RS-232	Baud rate	9600-115200
			Agreement	Full duplex mode, ASCII or binary format
	CAN	RS485	Baud rate	9600-115200
			Agreement	MODBUS RTU
			Baud rate	20kbit/s-1Mbit/s
	Protection function	CAN	Agreement	Canopen application layer DS-301V4.02
Equipment			Dsp-402 device driver and motion control	
Overvoltage, overcurrent, undervoltage, overload, overheating, encoder malfunction, excessive position tracking error, etc. protection.				
Using environment	Installation location		Non-corrosive gas, flammable gas, et	
	Altitude		Below 1000 m	
	Temperature		0°C~+50°C	
	Temperature		5%~95%RH, No condensation of water droplets	
	Resistance to vibration/impact		Less than 4.9m/s ² / less than 19.6m/s ²	

2、 Definition of wiring port

2.1 Mains three-phase input terminal J1

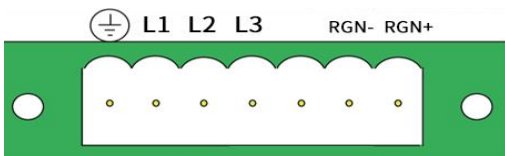

Figure 2.1.1 European gauge terminal socket

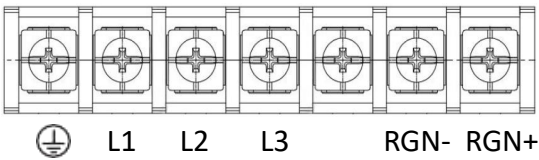

Figure 2.1.2 Fence terminal socket

L1	AC110V/220V
L2	
L3	
⊕	GND
RGN-	Brake Resistor Interface
RGN+	

2.2 Motor connector J2

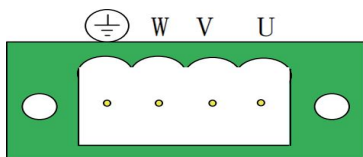

Figure 2.2.1 European gauge terminal socket

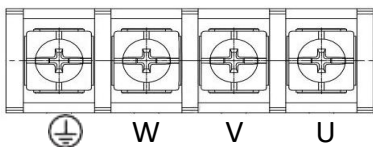

Figure 2.2.2 Fence terminal socket

U	Motor cable U
V	Motor cable V
W	Motor cable W
⊕	Motor cable PE

2.3 Internal 24v output terminal J3

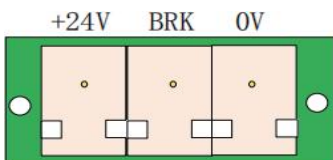

Figure 2.3 European gauge terminal socket

+24V	24v output 200mA (Do not supply power to the motor lock)
BRK	Connect the motor holding wire
0V	0V

2.4 Motor encoder input J4

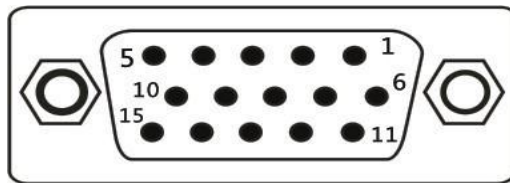

Figure 2.4 Three rows of DB15 female seats

Pin	Define	Function	Pin	Define	Function
1	A+	Motor encoder A+input	9	V+	Motor encoder V+ input
2	A-	Motor encoder A- input	10	NTC*	NTC 1/Temperature switch 1
3	B+(DAT+)	Motor encoder B+ input (Absolute value coder DAT+)	11	W+	Motor encoder W+ input
4	B-(DAT-)	Motor encoder B input (Absolute value coder DAT-)	12	IN5*	Temperature switch 2
5	Z+	Motor encoder Z+input	13	+5V	Motor signal line +5V
6	Z-	Motor encoder Z- input	14	0V	Motor signal cable GND
7	U+	Motor encoder U+input	15	NTC*	NTC 2
8					

Notes: 1. *For NTC resistor temperature sensor input function, connect pins 10 and 15. Please specify when placing your order.

2. *For temperature switch input function, connect pins 10 and 12. Please specify when placing your order.

2.5 Control signal I/O terminal J5

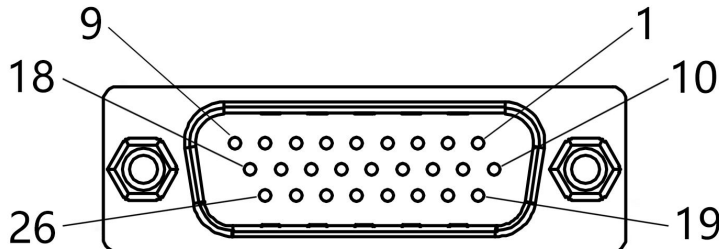

Figure 2.5 Three rows of DB26 male connector

Pin	Define	Function	Pin	Define	Function
1	FG	Grounding	14	OUT2	Custom
2	IN5	Motor temperature	15	OUT3	Custom
3	IN1	Enable	16	EONA+	Motor encoder output signal A+
4	IN2	Custom	17	EONA-	Motor encoder output signal A-
5	IN3	Custom	18	EONB+	Motor encoder output signal B+
6	IN4	Custom	19	EONB-	Motor encoder output signal B-
7	IN6	Custom	20	EONZ+	Motor encoder output signal Z+
8	IN7	Custom	21	EONZ-	Motor encoder output signal Z-
9	IN8	Custom	22	+5V	5V power output(400mA)
10	IN9	Custom	23	GND	Power ground
11	IN10	Custom	24	Ref+	Analog quantity + input
12	IN11	Custom	25	Ref-	Analog quantity - input
13	OUT1	Custom	26	IN12	Custom

2.6 CAN(RS485) communication terminal J6&J7

This drive has two communication ports, defined as follows:

One is a crystal head (default for CAN communication), and the other is a 6P terminal block (default for RS485 communication).

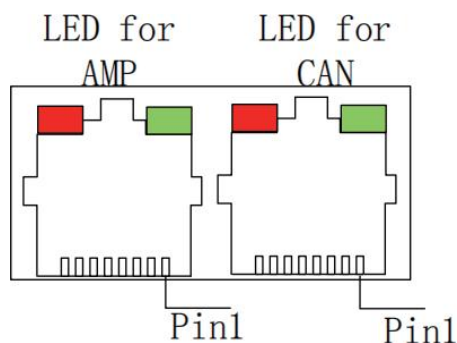

Figure 2.6.1 RJ45 8-pin crystal socket

Pin	Definition	Function
1	CANH (RS485_A)	CANH signal(RS485_A)
2	CANL(RS485_B)	CANL signal(RS485_B)
3/7	GND	Communication power grounding

Note: The two RJ45 ports in J6/J7 are defined in the same way to facilitate bridging during communication.

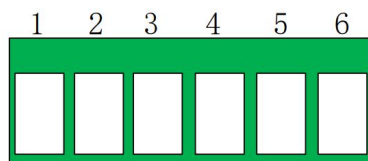

Figure 2.6.2 6P terminal

6P wiring terminals are defined as follows

Pin	Definition	Function
1	CANH (RS485_A)	CANH signal(RS485_A)
2	CANH (RS485_A)	CANH signal(RS485_A)
3	C_GND	Communication power grounding
4	C_GND	Communication power grounding
5	CANL(RS485_B)	CANL signal(RS485_B)
6	CANL(RS485_B)	CANL signal(RS485_B)

2.7 Definition of indicator Status

2.7.1 Drive status indicator (AMP)

Red/green leds tell us the status of the drive by changing color and blinking or not.

Possible scenarios include:

Green/no flash	drive is OK and enabled
Green/Slow blinking	drive is OK but not enabled. After enabled, it can run
Green/Flash	Positive limit switch or negative limit switch is effective, the motor will only move in the direction not prohibited by the limit switch
Red/Fixed	Instantaneous failure, after troubleshooting amplifier restart operation
Red/flashing	Lock the fault and restart the amplifier to resume operation

2.7.2 CAN Communication indicator (CAN)

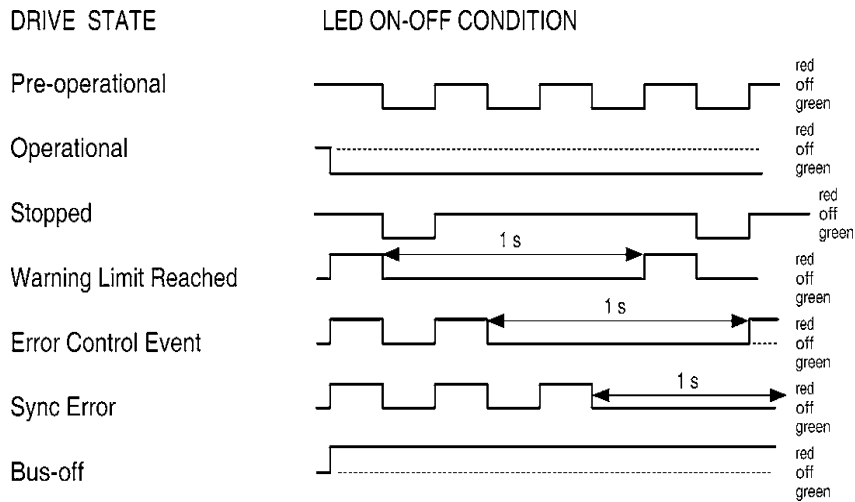

2.8 Serial communication terminal J8

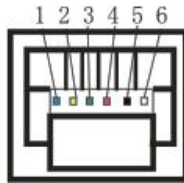
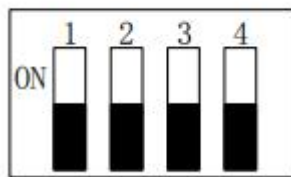

Figure 2.8 RJ11 6-pin crystal head holder

Pin	Definition	Function
2	RXD	RS232 communication receiver
3	GND	Communication power grounding
5	TXD	RS232 communication sender

2.9 SW Driver CAN address DIP switch

When the external DIP switch is selected for software Settings, the dip switch is effective. The switch encoding is in the BCD code sequence, and takes effect when the dip switch is switched to ON.



SW Indicates the station number of the DIP switch

SW switch Number	Corresponding stand No.
1	1
2	2
3	4
4	8

For example, if you want to set the station number to 3, switch the SW switch 1, 2 to ON and the other switch to OFF, $1+2=3$; If you want to set the station number to 12, dial SW 3,4 to ON, other to ooff, $4+8=12$

3、 Control port hardware description

3.1 RS-232 Communications (RXD, TXD, GND)

The serial ports are full-duplex and three-wire (RXD, TXD, GND)RS-232, with a baud rate from 9600 to 115200. The wiring terminal is J6 through the debugging software or serial port debugging tool. The debugging cables are shown as follows

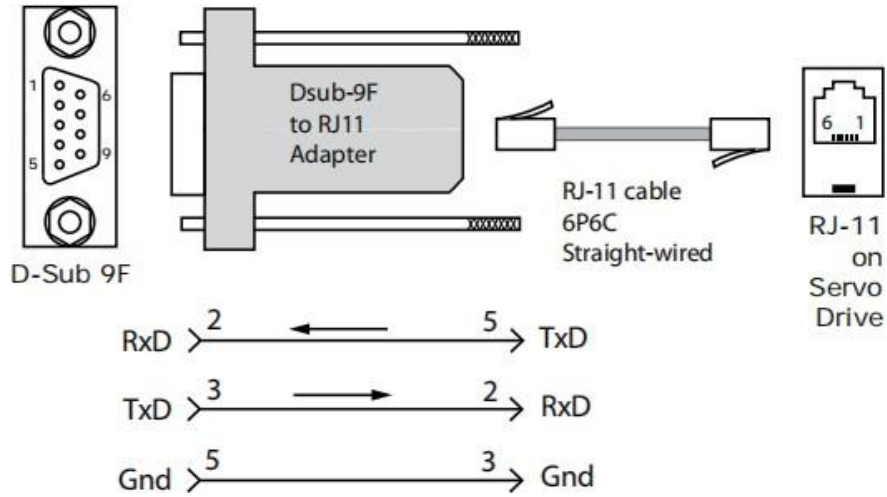

3.2 CAN bus (CANH,CANL,GND) and RS485 wiring

CAN bus is based on CAN V2.0B physical layer. The signals of CAN physical layer include CANH, CANL and GND, and communicate with CANopen protocol. Electrical interface uses TJA1051 high speed transceiver. The physical address of the drive CAN communication ranges from 0 to 127. The default address is 0. You can change the rS-232 communication port address, reset or restart the drive to take effect. Through the CAN communication interface, a very effective combination of high data rate and low cost multi-axis motion control system CAN be realized. The wiring terminal is J4/J5.The RS485 bus connection is the same as that of CAN.

CAN network CAN be connected as shown below:

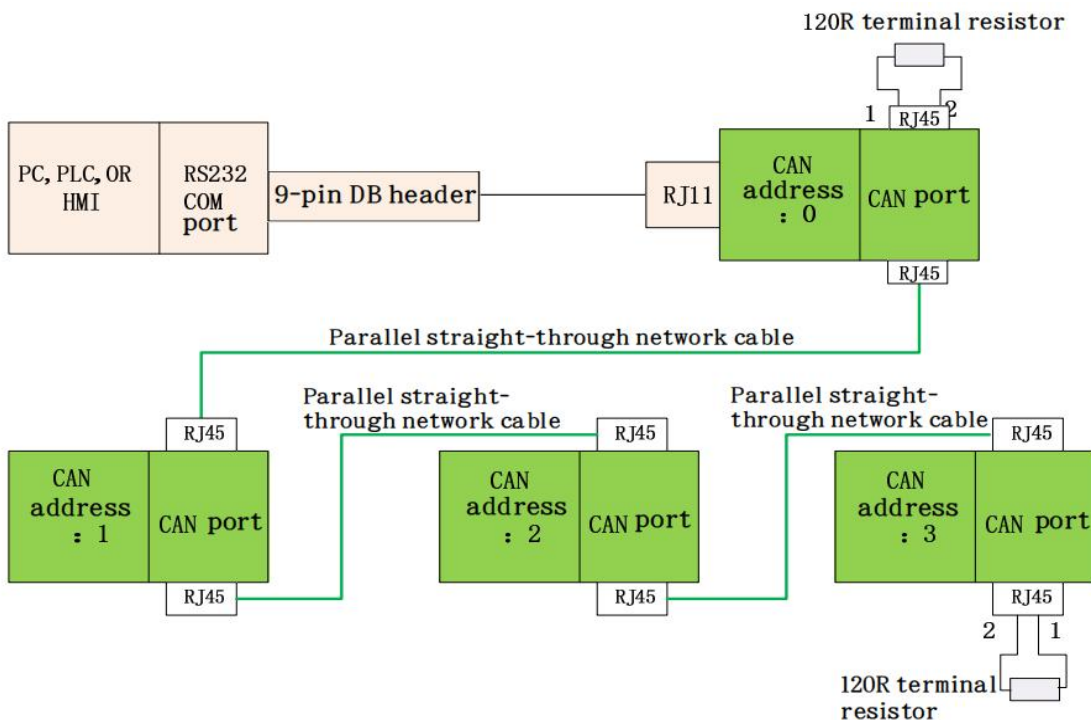

3.3 Analog signal input(Ref+,Ref-)

$\pm 10\text{Vdc}$ differential analog input, maximum input voltage $\pm 10\text{Vdc}$, input impedance about 5.36K , resolution 12 bits. The analog signal can be used for torque, speed and position control.

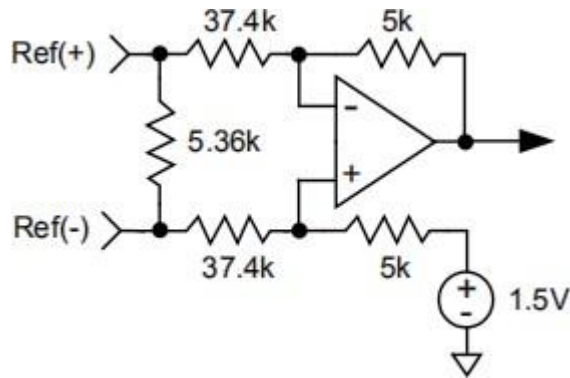

Figure 3.3.1 Analog hardware input circuit

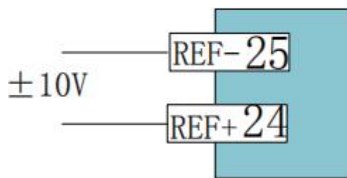

Figure 3.3.2 Analog input wiring of external power supply

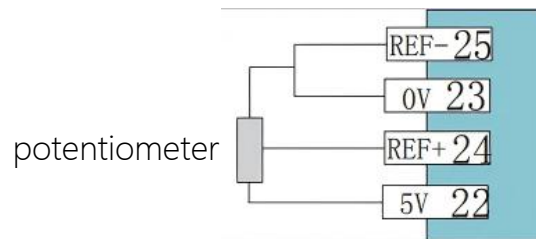

Figure 3.3.3 Analog input wiring of internal power supply

3.4 Digital input signal

BL series servo has 12 digital input ports, 11 have programmable function, drive power PWM output and security enable fixed by IN1 control, through this port can achieve power circuit hardware cut off.

According to the port function of controller and RC filtering time of hardware, the input signal port can be divided into universal input port and high-speed input port, and the function of each port can be changed programmatically.

3.4.1 Universal input signal terminal(IN1、IN2、IN3、IN4、IN5)

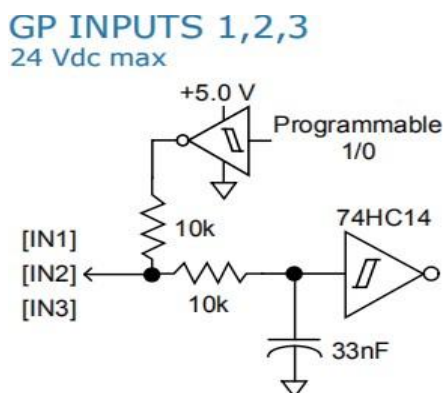

Figure 3.4.1 IN1-IN3 hardware input circuit

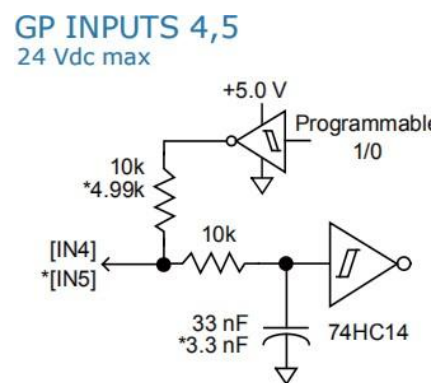

Figure 3.4.2 IN4-IN5 hardware input circuit

IN1, IN2, IN3, IN4, and IN5 are universal input signal terminals. The control logic and function can be set programmatically. IN1 is fixed for driver enable control, IN5 is mainly used for motor temperature protection input, through the software parameter setting high/low level takes effect.

3.4.2 High speed input signal terminal (IN6、IN7、IN8、IN9、IN10)

IN6, IN7, IN8, IN9, IN10 are high-speed input terminals. In addition to being used as general terminals, they can also be used as high speed pulse input. The pulse input port is fixed as (IN9, IN10).

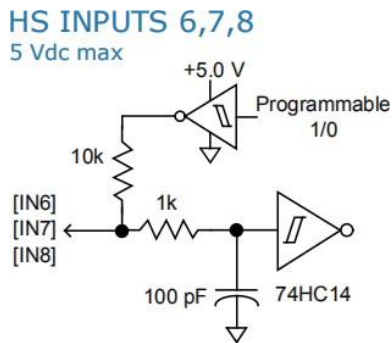

Figure 3.4.3 IN6,7,8 internal hardware diagram

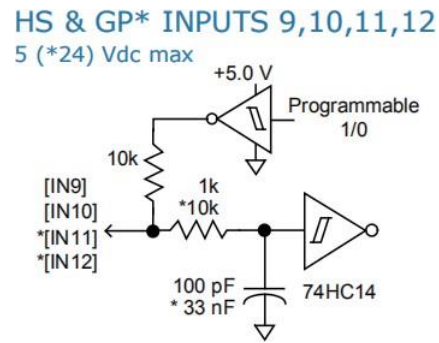

Figure 3.4.4 IN9,10,11,12 internal hardware diagram

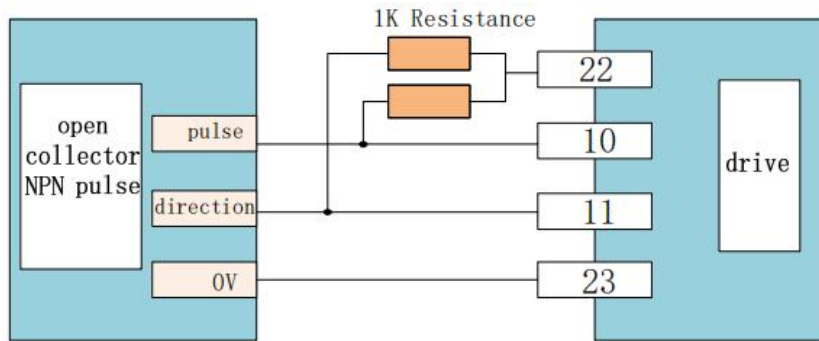

Figure 3.4.5 Open-collector NPN pulse input diagram

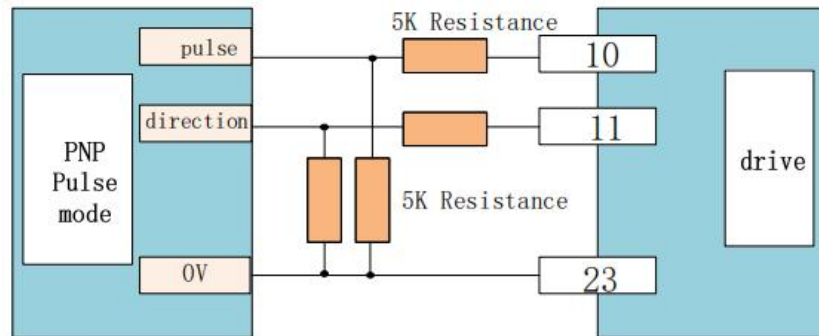

Figure 3.4.6 PNP pulse input diagram

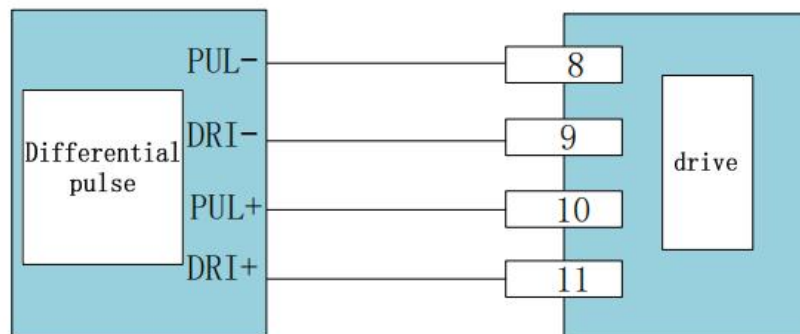

Figure 3.4.7 Differential Pulse Input Diagram

3.5 Digital output signal

BL series drivers have three digital output ports, digital output IO port MOSFET open output, internal through diode series 1K resistance to pull up to 5V, the port can withstand voltage to 24Vdc, the maximum current can withstand 300mAdc. The output function of the port can be changed according to internal programming.

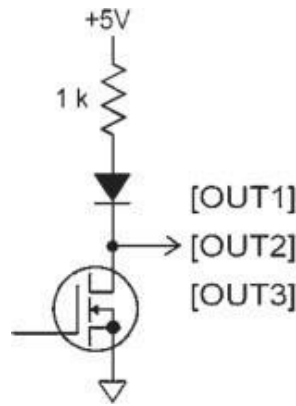

Figure 3.5 Digital output hardware circuit

3.6 PWM signal input

The motor can be controlled by PWM signal for speed and torque, including single-end PWM duty ratio + direction signal and single-end PWM duty ratio $\pm 50\%$ modulation.

3.6.1 Single PWM duty cycle = 0~100% pulse control

Duty cycle = 0 to 100%

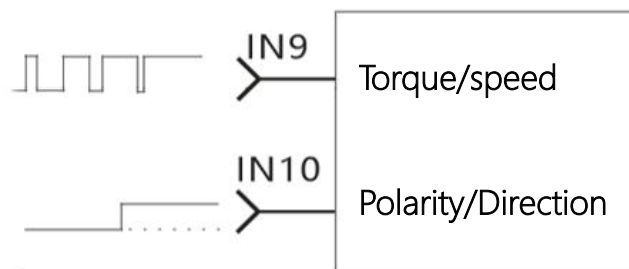

Figure 3.6.1 100% duty cycle + direction control

3.6.2 Single-end PWM duty cycle = 50%±50% pulse control

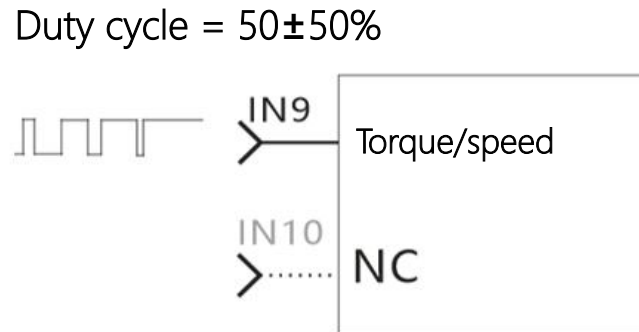

Figure 3.6.2 50%±50% duty cycle control

4、 Drive parameter Setting

BL series driver can set parameters, monitor motor state, collect data wave shape and so on through RS232 serial port. Complete system debugging quickly and intuitively. For details, see the instructions for Debugging Software.

5. System wiring diagram

Typical wiring diagram

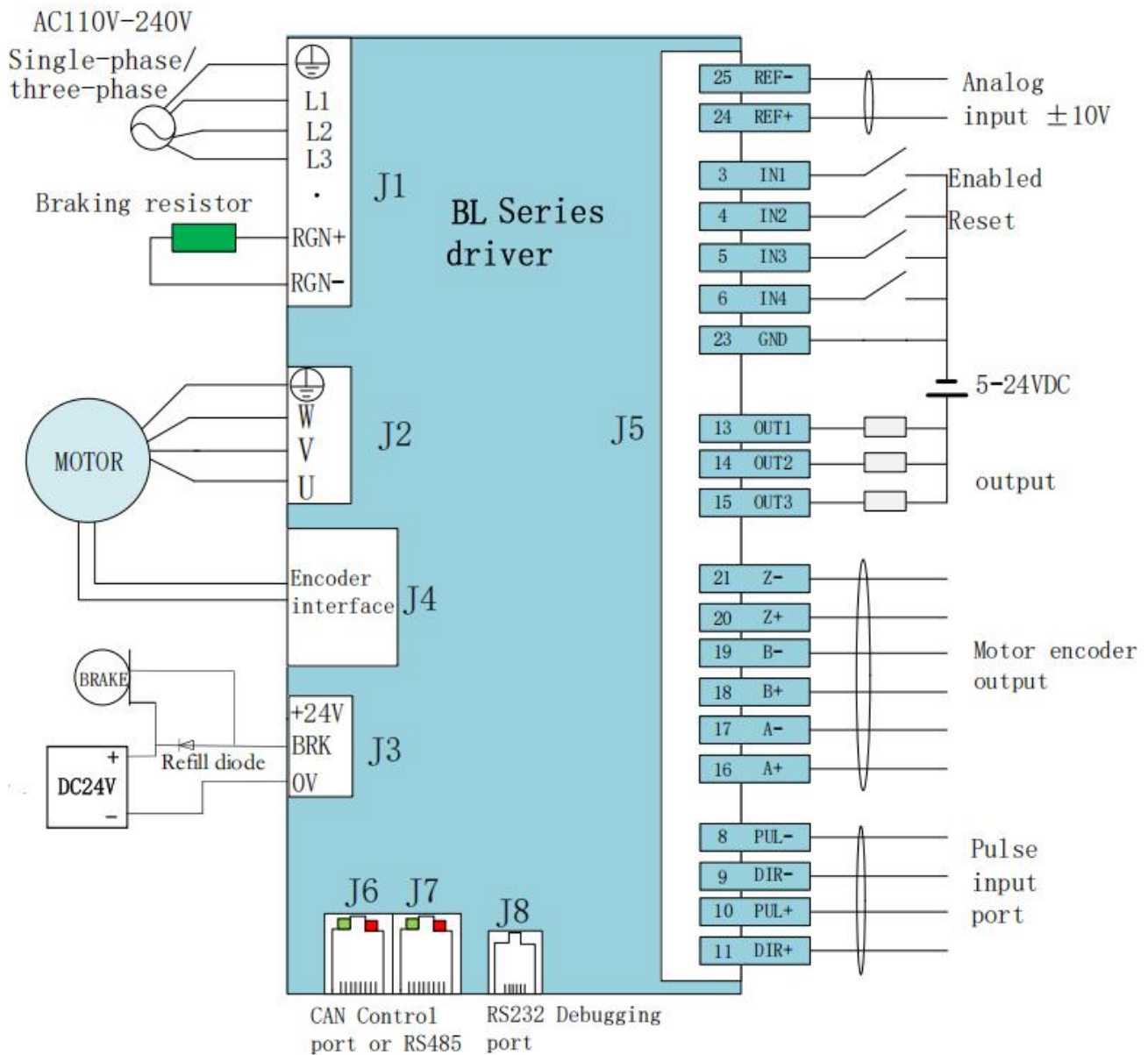

Description:

1. Input terminals IN1, IN2, IN3, IN4, IN5, IN 11, IN12 are common ports that can receive NPN and PNP signals. The maximum input voltage is 24V
2. IN6, IN7, IN8, IN9, IN10 are high-speed input ports with the highest input voltage of 5V

Contact Us

Shenzhen ONKE Technology Co.

Tel: 0755-27387873 27381841

Email: onke@sz-onk.com

Address: Block 13, Huaide Cuihu Industrial Park, Fuhai Street,
Baoan District, China

Revision record

Date	Version number	Revised content	
		Modify location	Modify content
20250825	V0.1	/	New edition