

Stable quality is fundamental to our survival

Quality service is the premise of our continued development

Customer satisfaction is our only goal

ONKE 欧诺克

Product gallery



Specialising in servo drives, servo motors and automation control systems.

DC Brushless Servo { Drive
Motor

Shenzhen ONKE Technology Co., Ltd.

Landline : 0755-27387873 27381841

Tel : Mr Deng 13538067106 Mr Chen 13929249379

Email : onke@sz-onk.com

Website : www.sz-onk.com www.onk168.com

Address : Block 13, Huai De Cui Hu Industrial Park, Fuhai Street,
Baoan District, Shenzhen City, Guangdong Province, China.

深圳市欧诺克科技有限公司
Shenzhen ONKE Technology Co., Ltd.

Directory

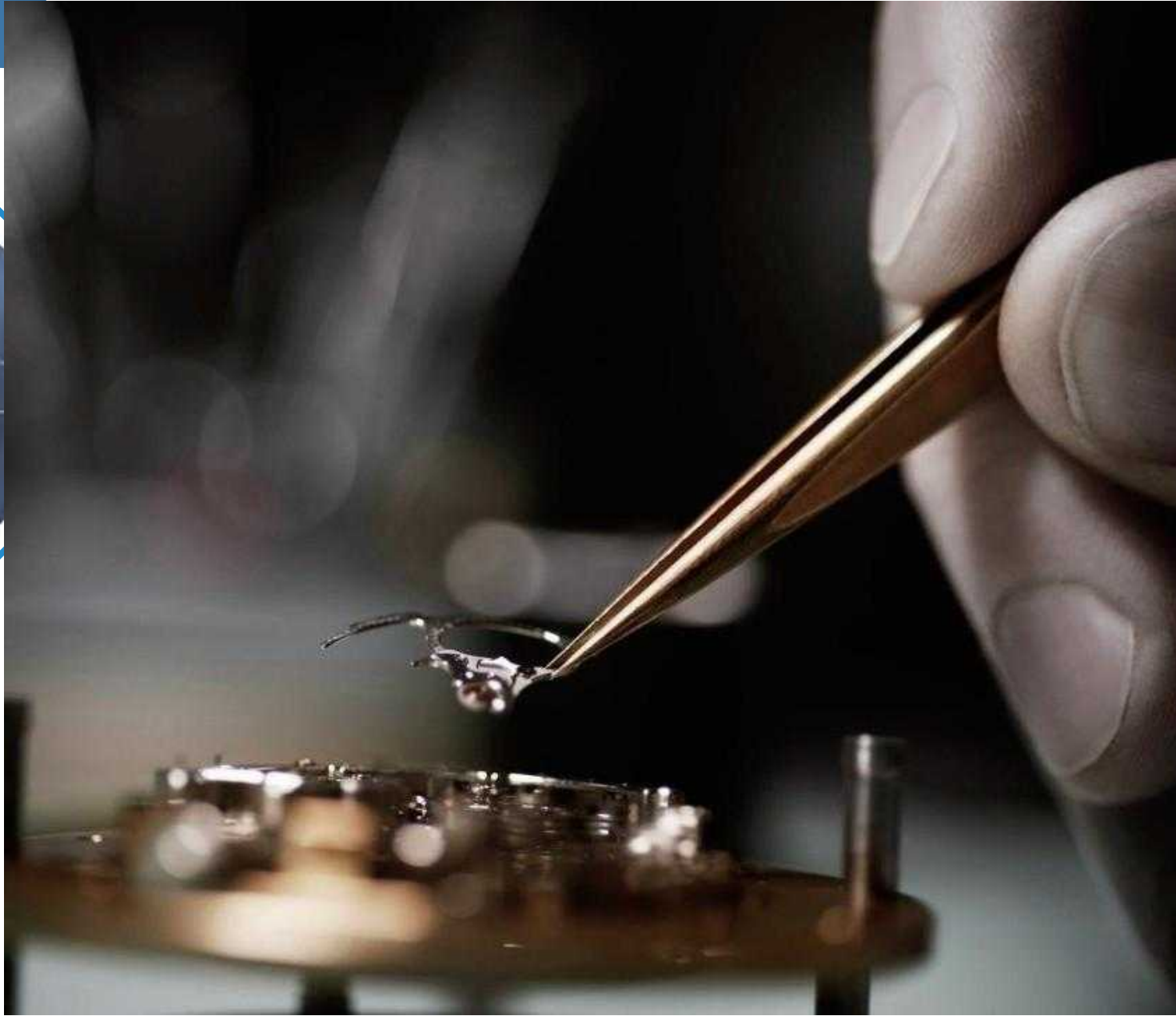

/// 匠心制造
Craftsmanship

精益求精
Excellence

Company Profile	01
I、DC brushless servo integrated machine.....	07
1. Product and model description.....	08
2. BY series technical index	09
II、DC Brushless Servo Drives.....	13
1. Drive description and model description.....	14
2. DC series technical index	17
3. DE series technical index.....	21
4. DE2 series technical index.....	25
5. BC series technical index.....	29
6. BC2 series technical index.....	33
7. DH DC series technical index.....	37
8. Driver Application Areas.....	41
9. Drive Peripheral Accessories.....	43
III、Dc brushless servo motor	45
1. Motor introduction and type description.....	45
2. Motor Application Areas.....	46
3. Motor Specification Parameter List.....	47
4. Motor specification size table.....	61



COMPANY PROFILE

Company Profile

Ltd. was founded in 2010, is a professional R & D production and sales of motors and drives of high-tech enterprises, research and development and production of cost-effective various types of motors and drives, keen insight into the market, with the times innovation to meet market demand.

Main business: DC servo drive, DC servo motor, AC servo drive, AC servo motor, linear motor drive, voice coil motor drive, DC brushless drive, DC brushless motor, steering wheel motor drive all-in-one, gearhead motor drive all-in-one, motor drive all-in-one, CANopen bus, EtherCAT bus, dedicated motion control servo system and automation control system. Over the past ten years, we have established mutually beneficial and win-win co-operation with many famous domestic and foreign companies by virtue of our exquisite technology.

Continuously research and develop all kinds of motors and actuators to meet the needs of 'mobile robot (AGV/AMR)' and other industries. Help customers to improve the quality of space and production efficiency. The spirit of customer service, service to society, for customers to solve problems as a responsibility, is the large and medium-sized enterprises preferred partner.

Company culture

Business philosophy: customer-centred! To meet the needs of our customers with honesty, high quality and satisfactory service.

Company goal: to create a first-class servo motor, drive manufacturers.

Company's values: achievement of customers, committed to customer satisfaction and success.

Entrepreneurial innovation: the pursuit of speed and efficiency, focusing on innovation that has an impact on customers and the company.

Precision and truthfulness: Fact-based decision-making and business management.

Honesty and Integrity: Build trust and responsible business.

Enterprise Mission: Continuous commitment to leading technology and service excellence for the enhancement of human manufacturing.

Enterprise Core: Responsibility is the root and integrity is the foundation.

Enterprise Spirit: Innovation changes the world, passion creates the future.

OUR TEAM

Our team

We are a professional team, our members have many years of servo drive, servo motor professional and technical background, from the domestic well-known servo drive, servo motor company's first-line backbone.

We are a young team, our average age is only 30 years old, full of vitality and innovative spirit. We are a dedicated team, we firmly believe that the brand of servo drives and servo motors comes from the trust of customers.

We are a dream team, we come from all over the world, because there is a common dream, to be a really good servo drive, servo motor enterprises, to provide customers with the most reliable servo drive, servo motor products.



Quality Control



Quality control is meticulous

Our mission

Implementing progress of precise transmission,
Help made in China.
Let mankind enjoy a better life and realize more dreams



Rigour is a pursuit, and excellence is an attitude!

With a complete production chain of servo drives and motors, the company has been practising the beauty of transmission for ten years without forgetting its original intention, and has made every effort to control the quality meticulously!



Patents for inventions

- ◆ Non-sinusoidal vibration drive control system



Utility model

- ◆ A simple economic servo drive
- ◆ A servo motor with electronically controlled contacts for easy welding
- ◆ A kind of wheel cutting flying shear servo system control component
- ◆ A kind of wheel cutting flying shear servo system controller
- ◆ A servo motor with controllable magnetic flux
- ◆ A DC bus servo drive

Software works

- ◆ CNC wire machine control system software V1.0
- ◆ CNC Screw Machine Control System Software V1.0
- ◆ CNC Wire Cutting Machine Control System Software V1.0
- ◆ CNC Shear Chase Control System Software V1.0
- ◆ Servo system debugging test software V1.0
- ◆ Intelligent Servo Drive Inspection and Maintenance Software V1.0



Comprehensive introduction of servo integrated machine

Comprehensive introduction of servo integrated machine

BY series servo all-in-one is a universal, high-performance, DC-powered, compact, all-digital servo drive all-in-one; brushless servo motors for position, speed, and torque control, and can support incremental encoders.

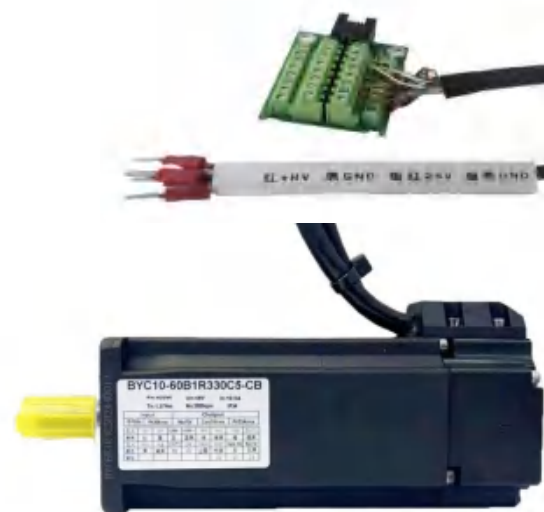

Servo machine model description

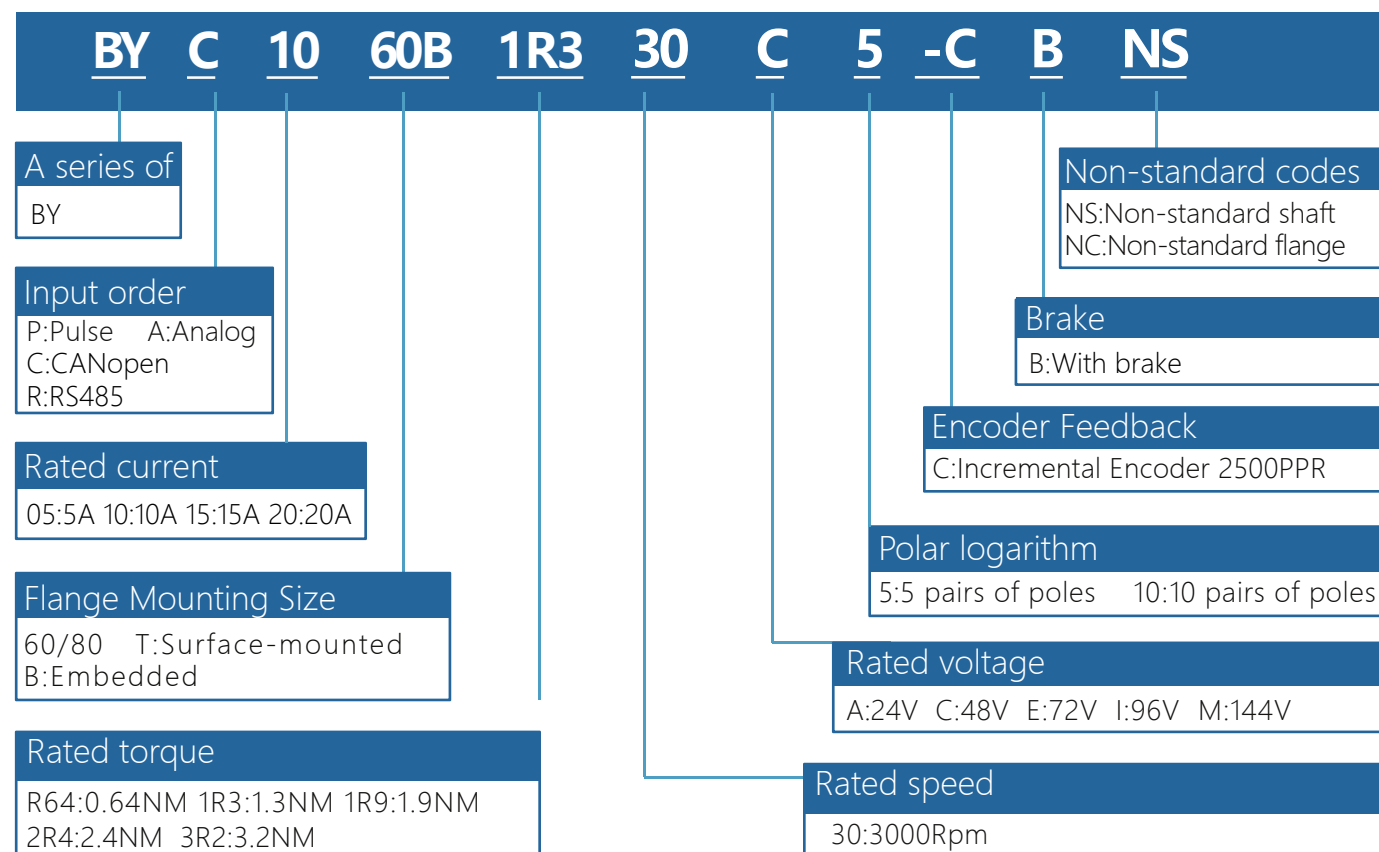

Servo integrated machine model description

Servomotor Drive All-in-One Model Summary

Model	Flange Size (mm)	Rated voltage (V)	Rated power (W)	Rated torque (N.m)	Rated RPM (rpm)	Rated current (Arms)	Control interface (optional)	Weight/kg		
BYC10-60BR6430A5-C	60	24	200	0.64	3000	10	CANopen RS485 脉冲 模拟量	1.05		
BYC10-60BR6430A5-CB								1.5		
BYC05-60BR6430C5-C								48	5	1.05
BYC05-60BR6430C5-CB										1.5
BYC05-60BR6430E5-C								72	3.5	1.05
BYC05-60BR6430E5-CB										1.5
BYC10-60B1R330C5-C		80	48	400		1.3		10	1.45	
BYC10-60B1R330C5-CB									1.9	
BYC10-60B1R330E5-C									72	7
BYC10-60B1R330E5-CB			1.9							
BYC10-60B1R930E5-C			72					10		
BYC10-60B1R930E5-CB									2.15	
BYC20-80B2R430C5-C	48	20		2.4	2.5					
BYC20-80B2R430C5-CB			3.3							
BYC15-80B2R430E5-C			72		13	2.4	2.5			
BYC15-80B2R430E5-CB	3.3									
BYC20-80B3R230E5-C	72	17		3.2			2.9			
BYC20-80B3R230E5-CB										
BYC15-80T1R930C10-C			48		600	1.9				
BYC15-80T1R930C10-CB	15									
BYC10-80T1R930E10-C	72	10		2.4						
BYC10-80T1R930E10-CB			20							
BYC20-80T2R430C10-C			48		750	2.4				
BYC20-80T2R430C10-CB	13									
BYC15-80T2R430E10-C	72	17		3.2			2.45			
BYC15-80T2R430E10-CB										
BYC20-80T3R230E10-C										
BYC20-80T3R230E10-CB										

BY Series Technical Specification

- ◆ Control mode: position, speed, torque;
- ◆ Programmable protection: position error, over current, over voltage or under voltage, I²t, output short circuit, overload and other multi-directional protection functions;
- ◆ Position feedback: Incremental encoder;
- ◆ RS232 serial interface, baud rate up to 115KB;
- ◆ RS485 MODBUS RTU serial interface, baud rate up to 115KB;
- ◆ CAN communication, compatible with CANopen DS-402, baud rate up to 1MHz;
- ◆ Only one RS485 or CAN can be selected;
- ◆ Power supply voltage: 18-70VDC, (18V-32VDC,18-90VDC customisable) ;

Position control	Command control mode		Servo enable, external reset, positive/reverse limit, motor running stop, high-speed analog acquisition control, PWM synchronous signal input, high-speed pulse input, etc	
	Input signal	Pulse instruction	Input pulse pattern	"direction + pulse"
			Signal format	Differential input, open collector
		Maximum pulse frequency	Differential input :(Max. 2Mpps) ; Open collector :(Max. 500Kpps)	
	Analog instruction	Voltage range	Input voltage range ±10V	
Input impedance		Differential input impedance=5KΩ		
Speed control	Command control mode		PWM、±10V analogue	
	Input signal	PWM	Polarity	PWM=0~100%, polarity=1/0
			Nonpolar	PWM=50% +/-50%
			Frequency range	Minimum 1 kHz, maximum 100 kHz
	Analog instruction	Minimum pulse width	220ns	
Voltage range		Input voltage range ±10V		
Input impedance	Differential input impedance=5KΩ			
Current control	Command control mode		PWM、±10V analogue	
	Input signal	PWM	Polarity	PWM=0~100%, polarity=1/0
			Nonpolar	PWM=50% +/-50%
			Frequency range	Minimum 1 kHz, maximum 100 kHz
	Analog instruction	Minimum pulse width	220ns	
Voltage range		Input voltage range ±10V		
Input impedance	Differential input impedance=5KΩ			
I/O signal	Digital input IN	Number of Ports	5 (IN4 and IN5 are high-speed ports, maximum voltage 12V), other inputs maximum input voltage 24V.	
		Signal format	NPN,PNP (Software sets input to be NPN or PNP)	
		Settable function	Servo enable, external reset, forward/reverse limit, motor run stop, high-speed analogue acquisition control, PWM synchronous signal input, etc.	
	Digital output OUT	Number of Ports	3	
		Signal format	NPN(low effective), can withstand a maximum current of 300mAdc, maximum voltage of 30Vdc	
Settable function	Fault signal, brake control, PWM sync signal, custom event track state, position trigger, program control			

Function	LED indicator		Drive status indication, communication indication	
	Communications functions	RS-232	Baud rate	9600-115200
			Agreement	Full duplex mode, ASCII or binary format
		RS485	Baud rate	9600-115200
	Agreement		MODBUS RTU	
	CAN	Baud rate	20kbit/s-1Mbit/s	
		Agreement	Canopen application layer DS-301V4.02	
Equipment		Dsp-402 device driver and motion control		
Protection function			Over-voltage,over-current,under-voltage,overload,overheat, encoder abnormality, position tracking error, etc. protection	
Use environment	Installation location		Non-corrosive gas, flammable gas, etc	
	Altitude		Below 1000 m	
	Temperature		-20°C~+50°C	
	Humidity		5%~95%RH, No condensation of water droplets	
	Resistance to vibration/impact		Less than 4.9m/s ² / less than 19.6m/s ²	
Feedback	Magnetically programmed incremental encoder (digital A/B quadrature)			

BY servo system wiring diagram

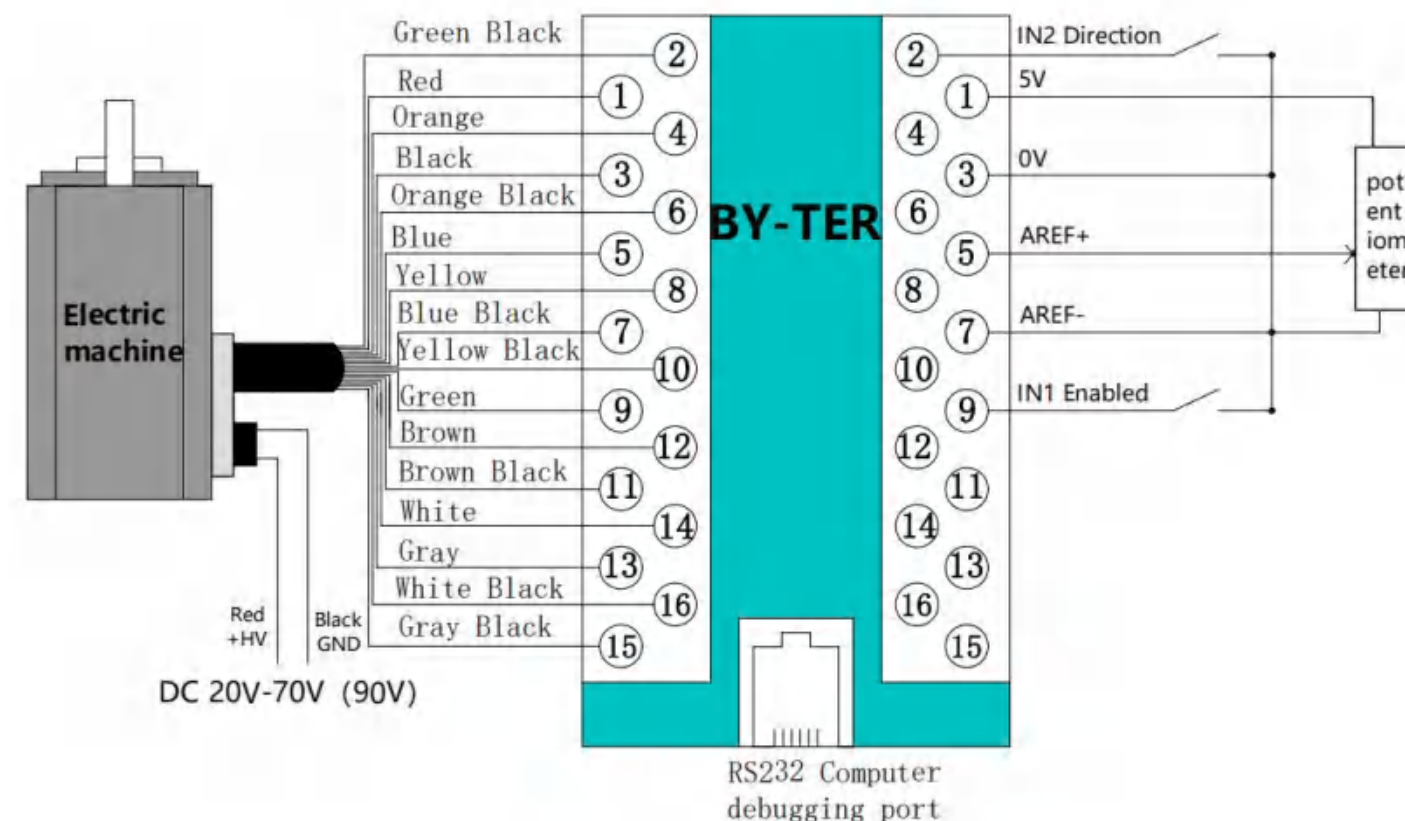



BY Series Terminal Definition

BY series power supply and holding brake wiring definition

Colour	Define	Power line	Instruction
Red	+HV		18VDC-70VDC
Black	GND		
Red (fine)	24V+		If there is a brake, it should be connected to the 24V power supply, if not, it does not need to be connected. (it can also be used as an auxiliary power input).
Black (fine)	GND		

Control signal I/O terminal (14/16 Core selectable)

Colour	Pin	Define	Control Cable	Terminal block		
Red	1	5V				
Black	3	0V				
Blue	5	AREF-(Analog-)				
Blue-black	7	AREF+(Analog+)				
Green	9	IN1(Enable)				
Green-black	2	IN2(Custom)				
Orange	4	IN3(Custom)				
Orange-black	6	OUT2(Custom)				
Yellow	8	IN5(DRI)				
Yellow-black	10	IN4(PUL)				
Brown	12	OUT1(Custom)				
White	14	CAN_L(485B)			Define the connecting terminal block by color pin.	The terminal blocks correspond to a group by serial number.
White-black	16	CAN_H(485A)				
brown-black	11	GND			Must be connected to pin 11 of the terminal block	This allows you to debug driver parameters using the RJ11 port on the terminal block.
Grey	13	RS232_RXD	Must be connected to pin 13 of the terminal block			
Grey-black	15	RS232_TXD	Must be connected to pin 15 of the terminal block			

Note: If the terminal block is not used, the excess core wire, need to be wrapped separately, do not short circuit or touch other metal objects.

BY All-in-one specification and size chart

60#

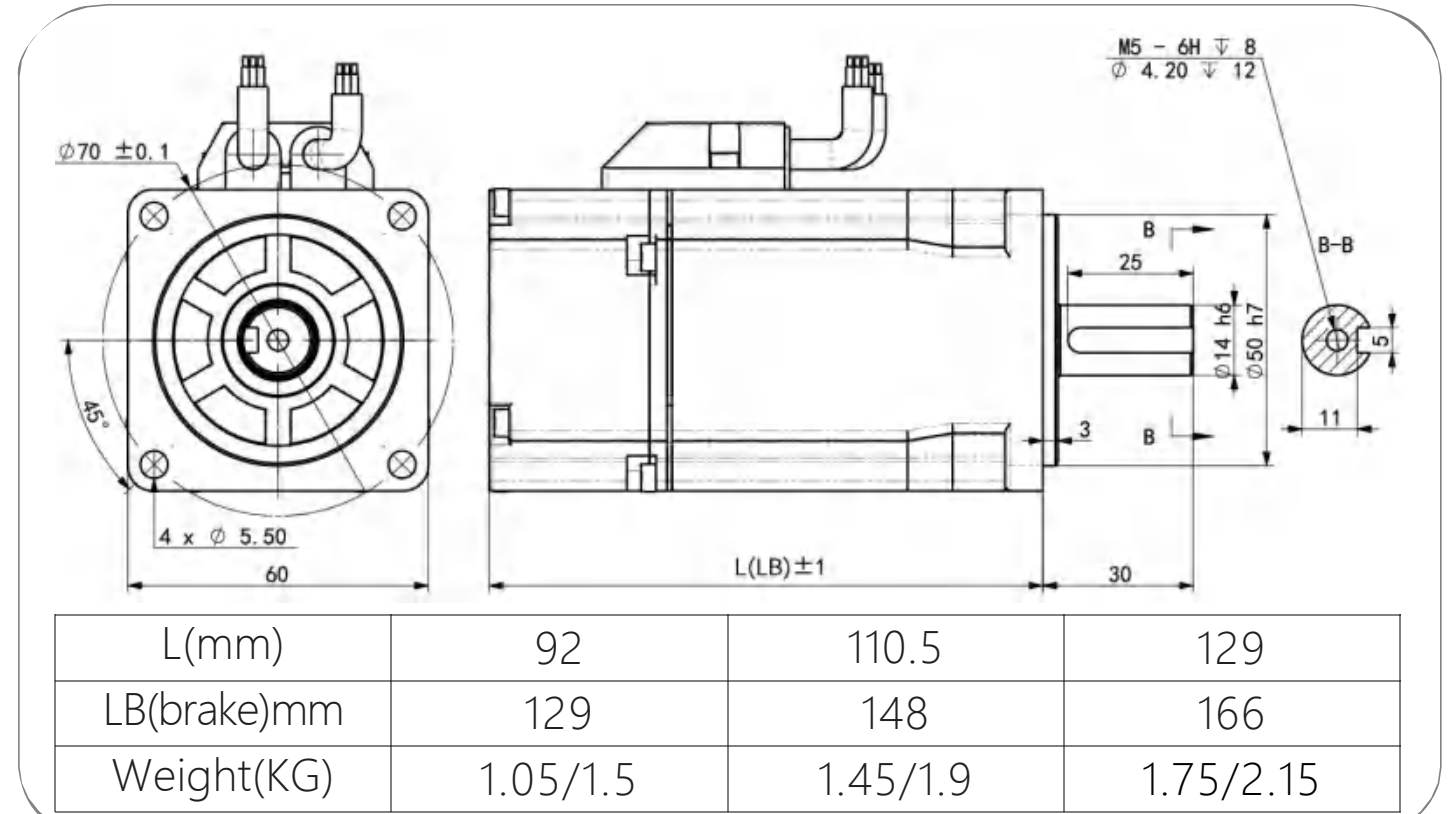

80#

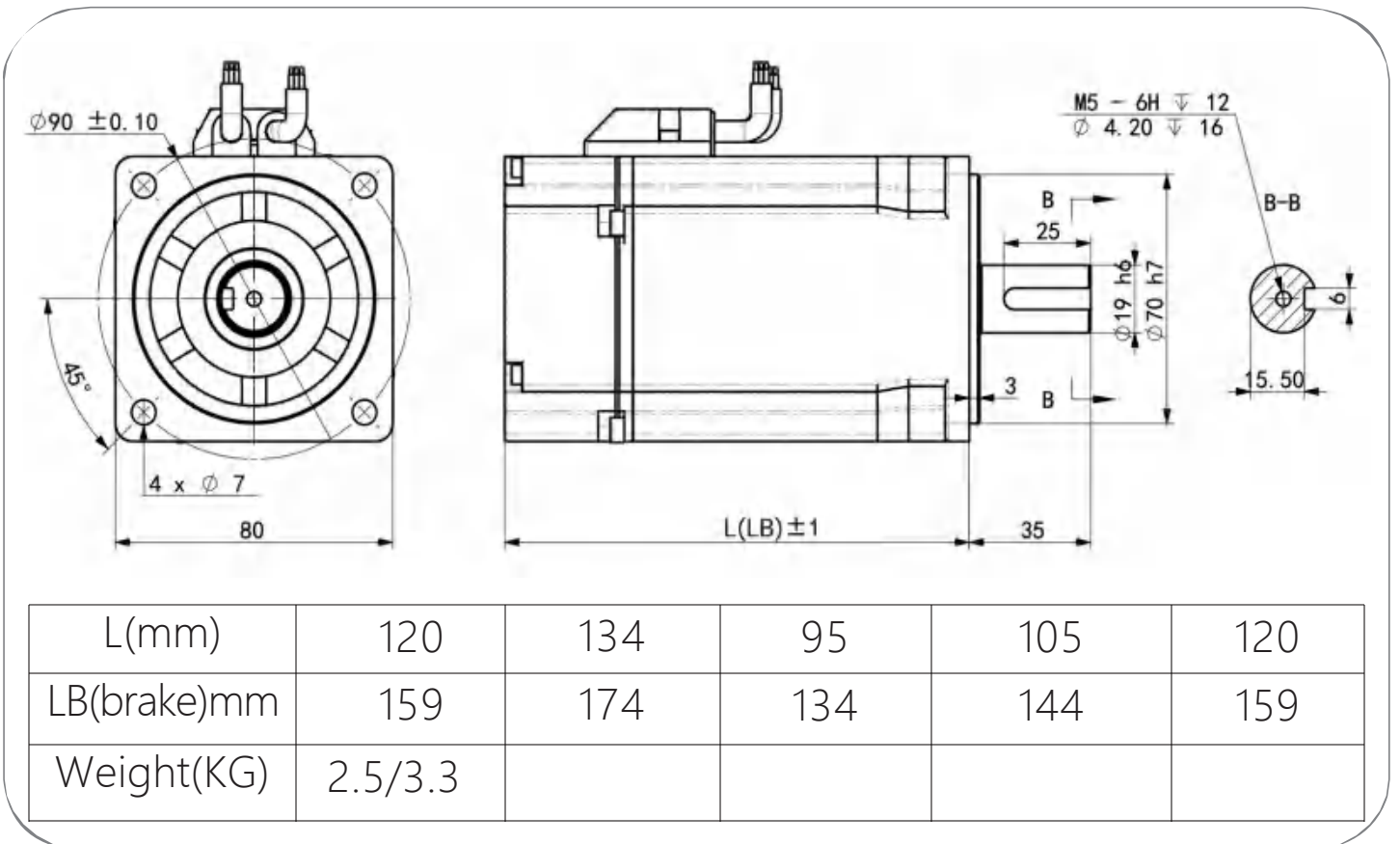

Servo Drive General Introduction

Servo Drive General Introduction

DC, DH, DE, DE2 and BC, BC2 series intelligent servo drive is a general-purpose, high-performance, DC-powered, compact, all-digital servo drive with maximum power up to 15KW, integrating programmable motion control, PLC, and servo drive functions. It is mainly used for position, speed and torque control of linear (DDL), torque (DDR), voice coil, brush and brushless servo motors. It can be operated in three modes: stand-alone programmable control (Stand-alone), external control, or distributed network (CAN (CANopen), EtherCAT, RS232, RS485 (plug-in)), and supports incremental encoders, analogue sine/cosine encoders, and absolute encoders of various protocols (Abs). Resolver, digital Hall feedback, and absolute encoders are also supported. The multi-mode encoder ports are used as inputs or outputs depending on the basic setup of the drive. Feedback from a secondary encoder is used as an input to create a dual-loop position control system.



Servo Drive Model Description

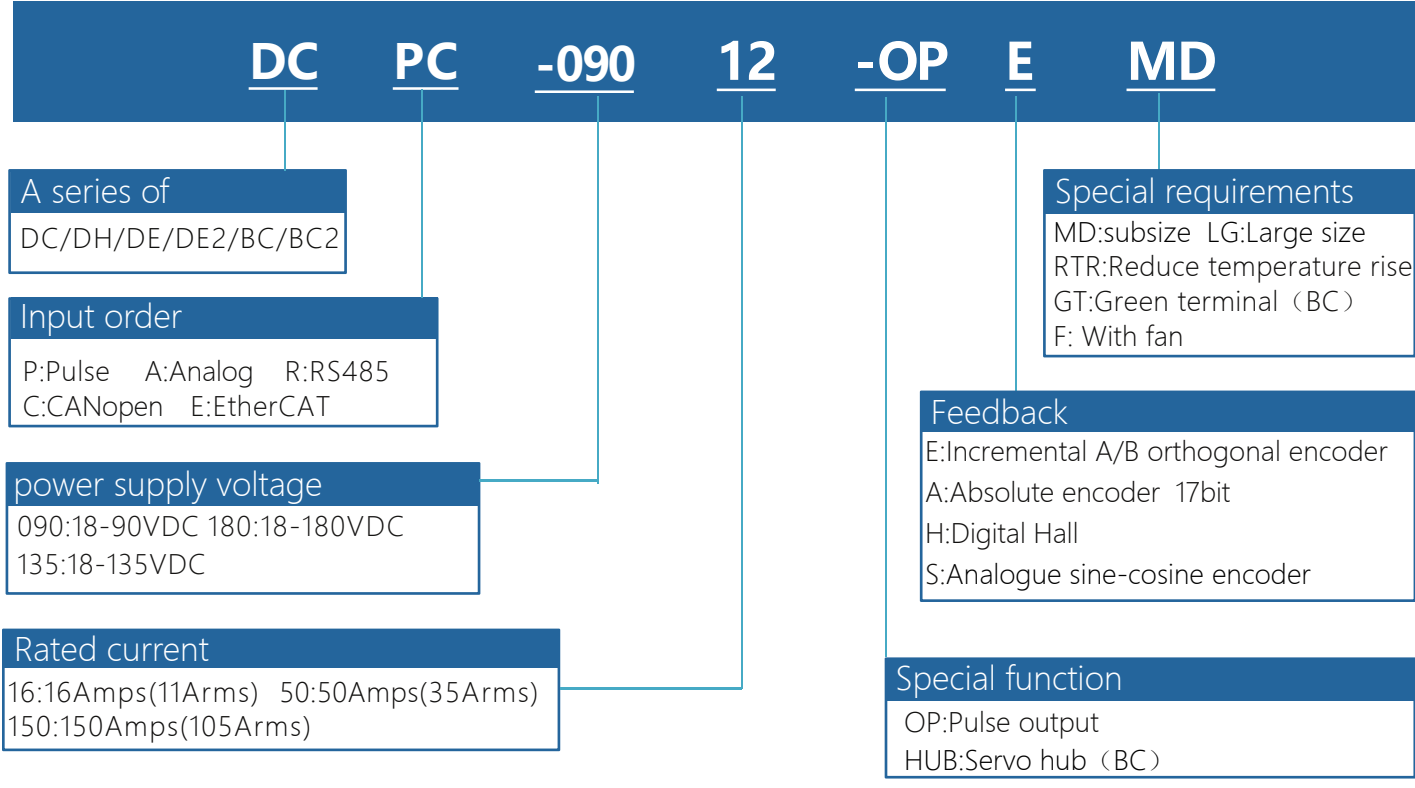

Attention to: 1.The driver supply voltage must be greater than or equal to the rated voltage of the motor.

2.The rated current of the driver must be greater than or equal to the rated current of the motor.

Servo Driver Model Description

DC&DH series drive specification summary table

Driver model	service voltage	Rated current Amps(Arms)	Peak current Apk(Arms)6S	Feedback type	Overall dimensions	Weight		
DCPC-09002-OPE	18~90 VDC	2A (1.4A)	6A (4.2A)	Incremental	141*90*32mm	0.35kg		
DCPC-09003-OPE		3A (2.1A)	9A (6.3A)					
DCPC-09004-OPE		4A (2.8A)	8A (5.6A)					
DCPC-09005-OPE		5A (3.5A)	10A (7A)		167*100*35mm	0.45kg		
DCPC-09008-OPE		8A (5.6A)	24A (16A)					
DCPC-09016-OPE		16A (11A)	48A (33A)					
DCPC-09024-OPE		24A (16A)	50A (35A)		200*114*59mm	1.10kg		
DCPC-09030-OPE		30A (21A)	60A (42A)					
DCPC-09040-OPE		40A (28A)	80A (56A)					
DCPC-09050-OPE		50A (35A)	100A (70A)		221*140*59mm	1.45kg		
DCPC-09075-OPE		75A (52A)	150A (105A)					
DCPC-090100-OPE		100A (70A)	200A (140A)					
DCPC-090125-OPE		125A(88A)	250A(177.5A)		221*140*85mm	1.8kg		
DCPC-090150-OPE		150A (105A)	250A (175A)					
DCPC-090200-OPE		200A (140A)	300A (210A)					
DCPC-090300-OPE-MD	18~180 VDC	300A (210A)	420A (294A)	Incremental	221*140*85mm	1.8kg		
DCPC-090300-OPE-LG		300A (210A)	420A (294A)					
DCPC-090350-OPE		350A (250A)	470A (330A)					
DCPC-18002-OPE		2A (1.4A)	6A (4.2A)		167*100*35mm	0.45kg		
DCPC-18003-OPE		3A (2.1A)	9A (6.3A)					
DCPC-18004-OPE		4A (2.8A)	8A (5.6A)					
DCPC-18005-OPE		5A (3.5A)	10A (7A)		200*114*59mm	1.10kg		
DCPC-18008-OPE		8A (5.6A)	24A (16A)					
DCPC-18016-OPE		16A (11A)	48A (33A)					
DCPC-18024-OPE		24A (16A)	50A (35A)		221*140*59mm	1.45kg		
DCPC-18050-OPE		50A (35A)	100A (70A)					
DCPC-18075-OPE		75A (52A)	150A (105A)					
DCPC-180100-OPE		18~135 VDC	100A (70A)		200A (140A)	Incremental	221*140*59mm	1.45kg
DCPC-180150-OPE			150A (105A)		250A (175A)			
DCPC-135100-OPE			100A (70A)		200A (140A)			
DCPC-135150-OPE	150 (105A)		250 (175A)	265*140*85mm	2.3kg			
DCPC-135200-OPE	200A (140A)		300A (210A)					
DCPC-125300-OPE	300A (210A)		420A (294A)					
DHPC-30005-OPEB-DC	160~390 VDC		5A(3.5A)	15A(10.5A)	Incremental		194*113.5*58mm	0.9kg
DHPC-30010-OPEB-DC			10A(7A)	20A(14A)				
DHPC-30015-OPEB-DC			15A(10A)	37.5(26.5A)				
DHPC-30020-OPEB-DC			20A(14A)	60A(42A)			204*140*60mm	1.2kg
DHPC-30025-OPEB-DC			25A(17A)	62.5A(44A)				
DHPC-30035-OPEB-DC			35A(24.5A)	105A(73.5A)				
DHPC-30050-OPEB-DC			50A(35A)	120A(84A)			204*140*80mm	1.9kg
DHPC-54005-OPEB-DC			5A(3.5A)	15A(10.5A)				
DHPC-54010-OPEB-DC			10A(7A)	30A(21A)				
DHPC-54015-OPEB-DC		350~690 VDC	15A(10A)	37.5A(26.5A)		Incremental	204*140*80mm	1.9kg
DHPC-54020-OPEB-DC			20A(14A)	60A(42A)				
DHPC-54025-OPEB-DC			25A(17A)	62.5A(44A)				
DHPC-54030-OPEB-DC			30A(21A)	70A(49A)			285*188*114mm	3.8KG
DHPC-54035-OPEB-DC			35A(24.5A)	70A(49A)				
DHPC-54005-OPEB-DC			5A(3.5A)	15A(10.5A)				
DHPC-54010-OPEB-DC	10A(7A)		30A(21A)	204*140*60mm	1.2kg			
DHPC-54015-OPEB-DC	15A(10A)		37.5A(26.5A)					
DHPC-54020-OPEB-DC	20A(14A)		60A(42A)					
DHPC-54025-OPEB-DC	25A(17A)		62.5A(44A)	204*140*80mm	1.9kg			
DHPC-54030-OPEB-DC	30A(21A)		70A(49A)					
DHPC-54035-OPEB-DC	35A(24.5A)		70A(49A)					

Servo Driver Model Description

Servo Driver Model Description

DE&DE2 series drive specification summary table

BC series drive specification summary table

Driver model	service voltage	Rated current Amps(Arms)	Peak current Apk(Arms)6S	Feedback type	Overall dimensions	Weight		
DEPC-09003-OPEA	18~90VDC	3A (2.1A)	6A (4.2A)	Incremental or Absolute value	167*100*35mm	0.45kg		
DEPC-09005-OPEA		5A (3.5A)	10A (7A)					
DEPC-09010-OPEA		10A (7A)	25A (17.5A)					
DEPC-09016-OPEA		16A (11A)	48A (33A)					
DEPC-09024-OPEA		24A (16A)	50A (35A)					
DEPC-09040-OPEA		40A (28A)	80A (56A)					
DEPC-09050-OPEA		50A (35A)	100A (70A)					
DEPC-09075-OPEA		75A (52A)	150A (105A)		200*114*59mm	1.10kg		
DEPC-090100-OPEA		100A (70A)	200A (140A)					
DEPC-090150-OPEA		150A (105A)	250A (175A)					
DEPC-090200-OPEA		200A (140A)	300A (210A)		221*140*85mm	1.8kg		
DEPC-090300-OPEA-MD		300A (210A)	420A (294A)					
DEPC-090300-OPEA-LG		300A (210A)	420A (294A)		265*140*85mm	2.3kg		
DEPC-090350-OPEA		350A (250A)	465A (330A)					
DEPC-18024-OPEA		18~180VDC	24A (16A)				50A (35A)	Incremental or Absolute value
DEPC-18050-OPEA			50A (35A)		100A (70A)			
DEPC-18075-OPEA			75A (52A)		150A (105A)	200*114*59mm	1.10kg	
DEPC-180100-OPEA	100A (70A)		200A (140A)					
DEPC-180150-OPEA	150A (105A)		250A (175A)	265*140*85mm	2.3kg			
DEPC-135100-OPEA	18~135VDC		100A (70A)			200A (140A)		
DEPC-135150-OPEA		150A (105A)	250A (175A)	221*140*85mm	1.8kg			
DEPC-135200-OPEA		200A (140A)	300A (210A)					
DE2PC-09016-OPEA	18~90VDC	16A (11A)	48A (33A)	Incremental or Absolute value	208*118*40mm	0.7kg		
DE2PC-09024-OPEA		24A (16A)	50A (35A)					
DE2PC-09040-OPEA		40A (28A)	80A (56A)					
DE2PC-09050-OPEA		50A (35A)	100A (70A)					
DE2PC-09075-OPEA		75A (52A)	150A (105A)		245*148*59mm	1.65kg		
DE2PC-090100-OPEA		100A (70A)	200A (140A)					
DE2PC-090150-OPEA		150A (105A)	250A (175A)					
DE2PC-18024-OPEA	18~180VDC	24A (16A)	50A (35A)	Incremental or Absolute value	208*118*40mm	0.7kg		
DE2PC-18050-OPEA		50A (35A)	100A (70A)					
DE2PC-18075-OPEA		75A (52A)	150A (105A)		245*148*59mm	1.65kg		
DE2PC-135100-OPEA	18~135VDC	100A (70A)	200A (140A)					

Driver model	service voltage	Rated current Amps(Arms)	Peak current Apk(Arms)6S	Feedback type	Overall dimensions	Weight
BCPC-09002-OPE/A	18~90VDC	2A	6A	Incremental or Absolute value	141*90*32mm	0.35kg
BCPC-09005-OPE/A		6A	18A			
BCPC-09010-OPE/A		11A	33A			
BCPC-09015-OPE/A		16A	50A		167*100*35mm	0.45kg
BCPC-09020-OPE/A		21A	50A			
BCPC-09030-OPE/A		30A	60A			
BCPC-09035-OPE/A		35A	70A			
BCPC-09050-OPE/A		50A	100A		200*114*59mm	1.10kg
BCPC-09070-OPE/A		70A	140A			
BCPC-09085-OPE/A		85A	170A			
BCPC-090100-OPE/A		100A	200A		221*140*59mm	1.45kg
BCPC-090140-OPE/A		140A	280A			
BCPC-090210-OPE/A-MD		210A	300A		221*140*85mm	1.8kg
BCPC-090210-OPE/A-LG		210A	300A			
BCPC-090250-OPE/A		250A	330A		265*140*85mm	2.3kg
BCPC-18015-OPE/A		18~180VDC	16A			
BCPC-18035-OPE/A			35A		70A	
BCPC-18050-OPE/A	50A		100A	167*100*35mm	0.45kg	
BCPC-18070-OPE/A	70A		140A			
BCPC-180100-OPE/A	100A		200A			
BCPC-13570-OPE/A	18~135VDC	70A	140A	200*114*59mm	1.10kg	
BCPC-135100-OPE/A		100A	200A			
BCPC-125210-OPE/A	18~125VDC	210A	300A	221*140*59mm	1.45kg	
				265*140*85mm	2.3kg	

BC2 series drive specification summary table

Driver model	service voltage	Rated current Amps(Arms)	Peak current Apk(Arms)6S	Feedback type	Overall dimensions	Weight
BC2PC-09001-OPE/A	18~90VDC	1A	3A	Incremental or Absolute value	141*90*36mm	0.35KG
BC2PC-09002-OPE/A		2A	6A			
BC2PC-09005-OPE/A		6A	18A			
BC2PC-09010-OPE/A		11.5A	34A			
BC2PC-09015-OPE/A		16A	48A			
BC2PC-09020-OPE/A		21A	50A			
BC2PC-09025-OPE/A-MD		25A	60A		204*126*52mm	0.9KG
BC2PC-09025-OPE/A-LG		25A	60A			
BC2PC-09035-OPE/A		35A	70A			
BC2PC-09050-OPE/A		50A	100A			
BC2PC-09050-OPE/AF		50A	100A			
BC2PC-09070-OPE/AF		70A	140A			
BC2PC-13550-OPE/A	18~135VDC	50A	100A	204*126*52mm	0.9KG	
BC2PC-13550-OPE/AF		50A	100A			
BC2PC-18010-OPE/A	18~180VDC	11A	33A	141*90*36mm	0.35KG	
BC2PC-18015-OPE/A		16A	48A			
BC2PC-18025-OPE/A		25A	50A			
BC2PC-18035-OPE/A		35A	70A	204*126*52mm	0.9KG	

DC Series Technical Specifications

DC Series Technical Specifications

- ◆ Control mode: position, speed, torque;
- ◆ Sampling frequency (time) Current loop: 15KHz(66.7us); Speed/Position Loop :3KHz(330μs);
- ◆ Bandwidth: the current loop is generally 2.5kHz, which varies with parameter adjustment and load inductance;
- ◆ Motion mode: electronic gear, electronic CAM, proportional linkage, point to point;
- ◆ Programmable protection: position error, over current, over voltage or under voltage, I²t, output short circuit overload and other multi-directional protection;
- ◆ Type of driving motor: three-phase stepping motor, brushless motor, brush motor, linear motor, voice coil motor, etc.;
- ◆ Position feedback: incremental encoder, Hall, grating ruler, analog sine and cosine (Sin/Cos) encoder(1.0Vp-p), rotary transformer (external conversion card);
- ◆ Pulse response frequency up to 2MHz, with digital filtering function;
- ◆ RS232 serial interface, baud rate up to 115KB;
- ◆ CAN2.0 local area bus, compatible with CANopen DS-402, baud rate up to 1MHz ;
- ◆ Power supply voltage: 18-90(135/180)VDC;



Position control	Command control mode		Servo enable, external reset, positive/reverse limit, motor stop, high-speed analog acquisition control, PWM synchronization signal input, high-speed pulse input, etc	
	Input signal	Pulse instruction	Input pulse pattern	The command can be direction + pulse, ORTHOGONAL pulse of A and B phases, and CW/CCW pulse.
			Signal format	Differential input, open collector
			Maximum pulse frequency	Differential input :(Max. 2Mpps) Open collector :(Max. 500Kpps)
	Analog instruction	Voltage range	Input voltage range ±10V	
Input impedance		Differential input impedance=5KΩ		
Speed control	Command control mode		PWM, ±10V analog, function generator, software programming	
	Input signal	PWM	Polarity	PWM=0~100%, polarity=1/0
			Nonpolar	PWM=50% +/-50%
			Frequency range	Minimum 1 kHz, maximum 100 kHz
			Minimum pulse width	220ns
Analog instruction	Voltage range	Input voltage range ±10V		
Input impedance	Differential input impedance=5KΩ			
Current control	Command control mode		PWM, ±10V analog, function generator, software programming	
	Input signal	PWM	Polarity	PWM=0~100%, polarity=1/0
			Nonpolar	PWM=50% +/-50%
			Frequency range	Minimum 1 kHz, maximum 100 kHz
			Minimum pulse width	220ns
Analog instruction	Voltage range	Input voltage range ±10V		
Input impedance	Differential input impedance=5KΩ			
I/O signal	Digital input IN		Number of Ports	10(IN6, IN7, IN8, IN9 and IN10 are high-speed ports, IN5 is used for motor temperature protection)
			Signal format	NPN(low active)
			Settable function	Servo enable, external reset, positive/reverse limit, motor stop, high-speed analog acquisition control, PWM synchronization signal input, high-speed pulse input, etc
	Digital output OUT		Number of Ports	3
			Signal format	NPN(low effective), can withstand a maximum current of 300mAdc, maximum voltage of 30Vdc
Settable function	Fault signal, brake control, PWM sync signal, custom event track state, position trigger, program control			

DC Series Technical Specifications

Function	LED indicator		Drive status indication, communication indication	
	Communications functions	RS-232	Baud rate	9600-115200
		Agreement	Full duplex mode, ASCII or binary format	
	CAN	Baud rate	20kbit/s-1Mbit/s	
Agreement		Canopen application layer DS-301V4.02		
Equipment	Dsp-402 device driver and motion control			
Protection function		Overvoltage, overcurrent, undervoltage, overload, overheating, abnormal encoder, too large position tracking error and other protection		
Use environment	Installation location		Non-corrosive gas, flammable gas, etc	
	Altitude		Below 1000 m	
	Temperature		-20°C~+50°C	
	Humidity		5%~95%RH, No condensation of water droplets	
	Resistance to vibration/impact		Less than 4.9m/s ² / less than 19.6m/s ²	
Feedback	Digital A/B quadrature encoder (-E, max. 5M line/s)			
	Auxiliary encoder input/output (full closed-loop control/-OP)			
	Analogue sin/cos encoder (-S) optional			
	Rotary Transformer(-R) Optional			
	Digital Hall (-H (U/V/W, 120 degrees electrical phase difference)			

DC Typical wiring diagram

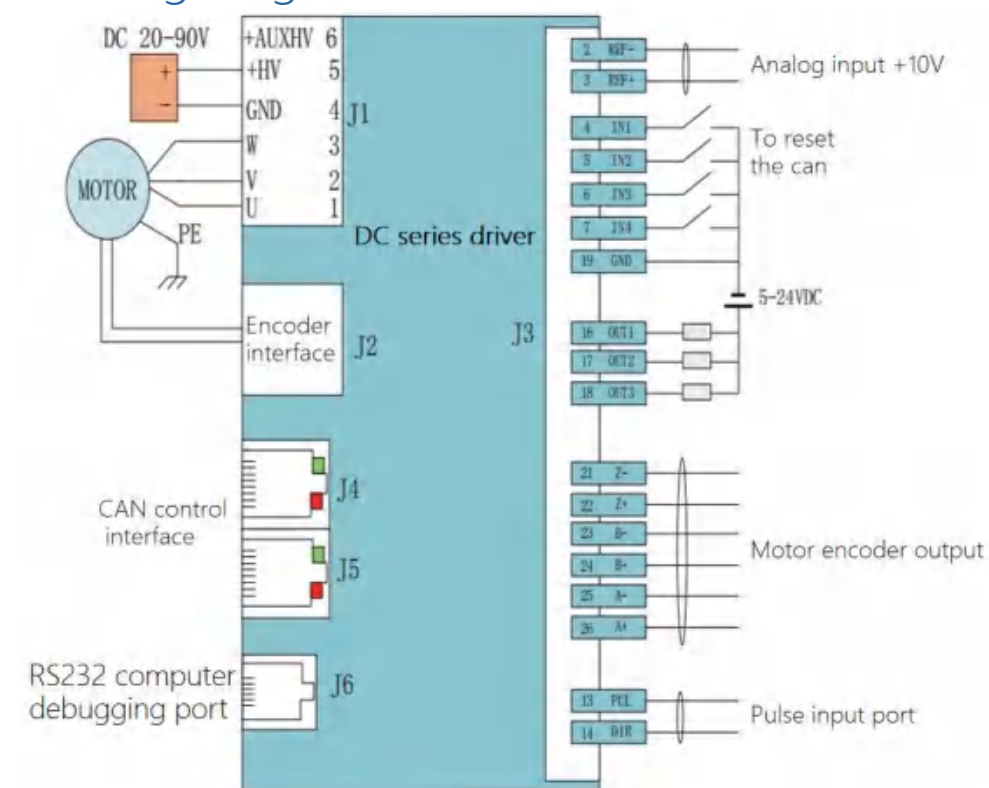

Description:

1. Input terminals IN1,IN2,IN3,IN4,IN5,IN 11,IN12 are common ports that can receive NPN and PNP signals. The maximum input voltage is 24V;
2. IN6, IN7,IN8,IN9,IN10 are high-speed input ports with the highest input voltage of 5V;
3. AUXHV is an auxiliary power supply, which can be connected if necessary. If connected, communication is maintained when +HV is disconnected and +AUXHV is powered on, but there is no action when issuing commands.

DC Series Terminal Definition

DC Series Terminal Definition

J6 RS-232 Debugging

PIN	Define
1	NO Connection
2	RxD
3	Signal Ground
4	Signal Groudn
5	TxD
6	NO Connection

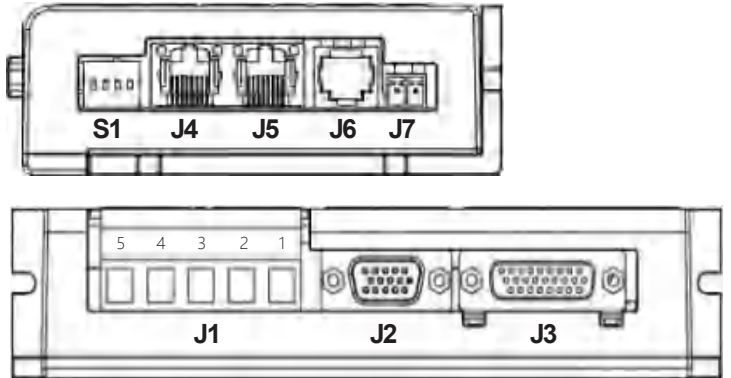

J4-J5 CAN communication link

PIN	Define
1	CAN_H
2	CAN_L
3	CAN_GND
4	No Connection
5	Reserved
6	(CAN_SHLD) ¹
7	CAN_GND
8	(CAN_V+) ¹

J1 Motor Power

PIN	Define
1	U
2	V
3	W
4	0V
5	DC20-90V

J7 Auxiliary power supply

GND	0V
+AUXHV	+24V (or ≤ mains voltage)

J3 Control signal terminal

PIN	Define	PIN	Define	PIN	Define
1	Grounding	10	[IN6] custom	19	0V
2	Analog quantity - input	11	[IN7] custom	20	+5V
3	Analog quantity + input	12	[IN8] custom	21	Motor encoder Z- input
4	[IN1] Enable	13	[IN9] custom	22	Motor encoder Z+ input
5	[IN2] custom	14	[IN10] custom	23	Motor encoder B- input
6	[IN3] custom	15	[IN5] Motor temperature	24	Motor encoder B+ input
7	[IN4] custom	16	[OUT1] custom	25	Motor encoder A- input
8	[IN11] custom	17	[OUT2] custom	26	Motor encoder A+ input
9	[IN12] custom	18	[OUT3] custom		

DC Series outline dimension drawing

J2 Motor encoder feedback

PIN	Define	PIN	Define	PIN	Define
1	SIN+	6	V+	11	B-
2	SIN-	7	Z-	12	B+
3	U+	8	Z+	13	A-
4	+5 V	9	W+	14	A+
5	0V	10	COS+	15	COS-

SW Indicates the station number of the DIP switch

SW switch Number	Corresponding stand no
1	1
2	2
3	4
4	8

DC Series External Dimensions

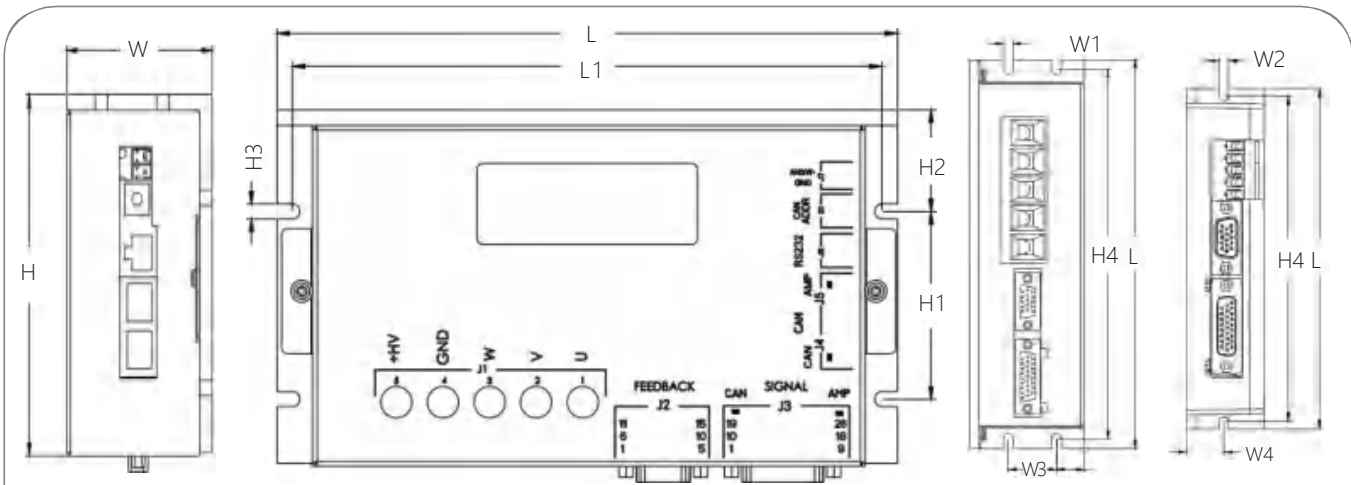

Model	L	L1	W	W1	W2	W3	W4	H	H1	H2	H3	H4
DCPC-2A~24A	141	134	32	/	4.5	/	15.5	90	51	18	4.5	134
DCPC-30A~50A	167	160	35	/	2-4.5	/	19.5	100	51	22	4-4.5	160
DCPC-75A100A	200	190	59	4-5.0	/	25	/	114	60	32.5	4-4.8	190
DCPC-100AF	200	190	59	4-5.0	/	25	/	114	60	32.5	4-4.8	190
DCPC-150A	221	211	59	5	/	25	/	140	60	45	4.8	211
DCPC-150AF	221	211	59	5	/	25	/	140	60	45	4.8	211
DCPC-200A	221	211	85	5	/	25	/	140	/	/	/	211
DCPC-300A	221	211	85	5	/	25	/	140	/	/	/	211

DE Series Technical Specifications

DE Series Technical Specifications

- ◆ Control mode: position, speed, torque;
- ◆ Sampling frequency (time) Current loop: 16KHz(62.5us); Speed/Position Loop :4KHz(250μs)
- ◆ Bandwidth: the current loop is generally 2.5kHz, which varies with parameter adjustment and load inductance;
- ◆ Programmable protection: position error, over current, over voltage or under voltage, I²t, output short circuit overload and other multi-directional protection functions;
- ◆ Type of driving motor: brushless motor, brush motor, linear motor, voice coil motor, etc.;
- ◆ Encoder feedback: incremental encoder, Hall, grating ruler, rotary transformer (plus conversion card); Absolute encoder, support SSI, Absolute A, BiSS(B&C) protocol;
- ◆ Pulse response frequency up to 2MHz, with digital filtering function;
- ◆ RS232 serial interface, baud rate up to 115KB;
- ◆ CAN2.0 local area bus, compatible with CANopen DS-402, baud rate up to 1MHz; Support PVT, back to zero, interpolation;
- ◆ EtherCAT Ethernet Fieldbus, used as EtherCAT slave using CANopen application protocol, supports cyclic synchronous position-speed-Torque (CSP-CSV-CST),PVT, interpolation, and zero back for DSP-402 motion control devices with EtherCAT(CoE) protocol;
- ◆ Power supply voltage: 20-90(135/180)VDC;



Position control	Command control mode		Servo enable, external reset, positive/reverse limit, motor stop, high-speed analog acquisition control, PWM synchronization signal input, high-speed pulse input, etc	
	Input signal	Pulse instruction	Input pulse pattern	The command can be direction + pulse, ORTHOGONAL pulse of A and B phases, and CW/CCW pulse.
			Signal format	Collector open circuit
		Maximum pulse frequency	Biggest 2 Mpps	
Analogue instruction	Voltage range	Input voltage range ±10V		
		Input impedance	Differential input impedance=5KΩ	
Speed control	Command control mode		PWM, ±10V analog, function generator, software programming	
	Input signal	PWM	Polarity	PWM=0~100%, polarity=1/0
			Nonpolar	PWM=50% +/- 50%
			Frequency range	Minimum 1 kHz, maximum 100 kHz
Minimum pulse width	220ns			
Analogue instruction	Voltage range	Input voltage range ±10V		
		Input impedance	Differential input impedance=5KΩ	
Current control	Command control mode		PWM, ±10V analog, function generator, software programming	
	Input signal	PWM	Polarity	PWM=0~100%, polarity=1/0
			Nonpolar	PWM=50% +/- 50%
			Frequency range	Minimum 1 kHz, maximum 100 kHz
Minimum pulse width	220ns			
Analogue instruction	Frequency range	Minimum 1 kHz, maximum 100 kHz		
		Minimum pulse width	220ns	
I/O signal	Digital input IN		Number of Ports	10(IN6, IN7, IN8, IN9 and IN10 are high-speed ports, IN5 is used for motor temperature protection)
			Signal format	NPN(low active)
	Digital output OUT		Settable function	Servo enable, external reset, positive/reverse limit, motor stop, high-speed analog acquisition control, PWM synchronization signal input, high-speed pulse input, etc
			Number of Ports	3
		Signal format	NPN(low effective), can withstand a maximum current of 300mA dc, maximum voltage of 30Vdc	
		Settable function	Fault signal, brake control, PWM sync signal, custom event track state, position trigger, program control	

DE Series Technical Specifications

Function	LED indicator		Drive status indication, communication indication	
	Communications functions	RS-232	Baud rate	9600-115200
			Agreement	Full duplex mode, ASCII or binary format
		CAN	Baud rate	20kbit/s-1Mbit/s
Agreement	Canopen application layer DS-301V4.02			
	Equipment	Dsp-402 device driver and motion control		
	EtherCAT	Agreement	CoE, CiA-402	
Use environment	Protection function		Overvoltage, overcurrent, undervoltage, overload, overheating, abnormal encoder, too large position tracking error and other protection	
	Installation location		Non-corrosive gas, flammable gas, etc	
	Altitude		Below 1000 m	
	Temperature		-20°C~+50°C	
	Humidity		5%~95%RH, No condensation of water droplets	
Feedback	Resistance to vibration/impact		Less than 4.9m/s ² / less than 19.6m/s ²	
	Digital A/B quadrature encoder (-E, max. 5M line/s)			
	Auxiliary encoder input/output (full closed-loop control/-OP)			
	Rotary Transformer(-R) Optional			
	Digital Hall (-H (U/V/W, 120 degrees electrical phase difference)			
Absolute encoder (A17) optional				

DE Typical wiring diagram

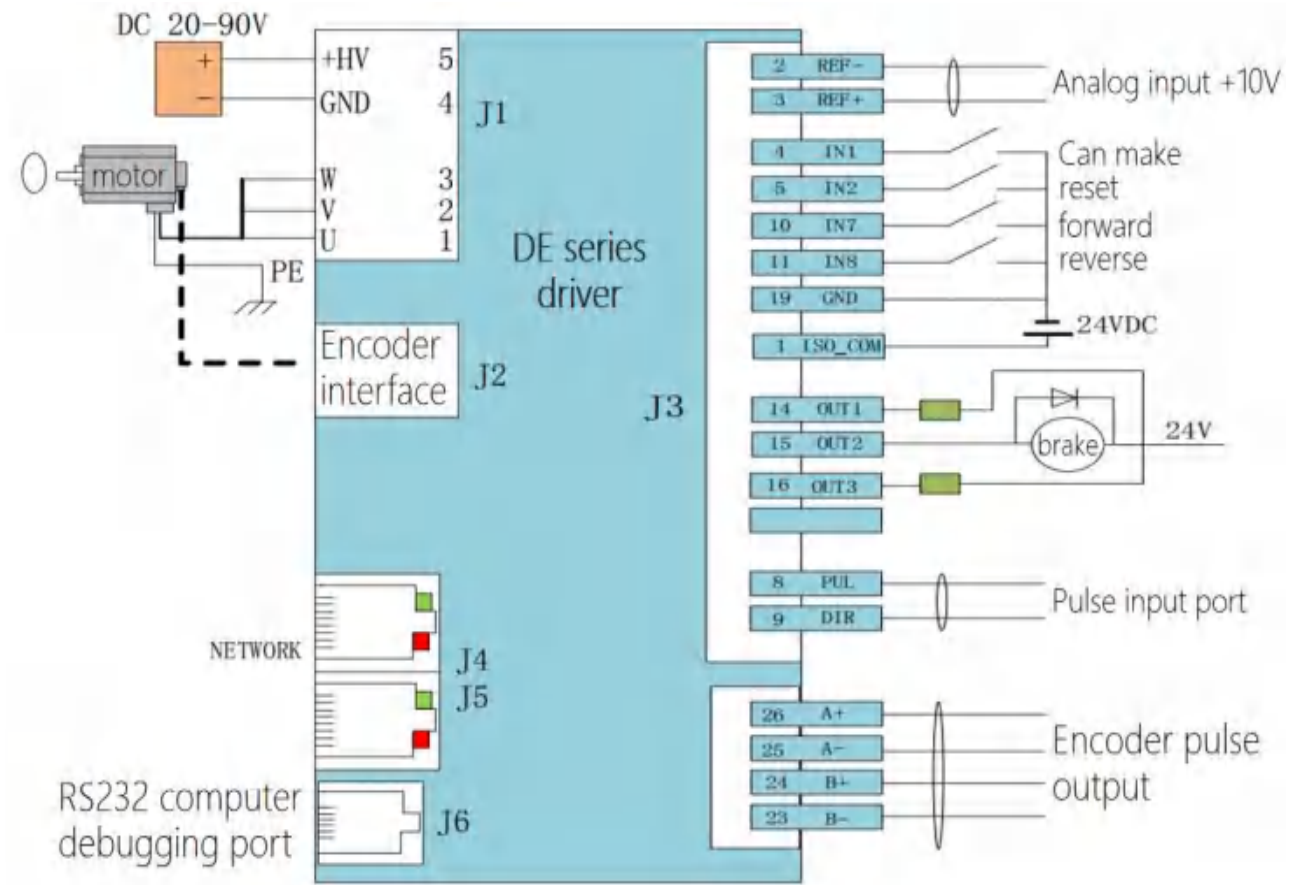

DE Series Terminal Definition

DE Series Terminal Definition

J6 RS-232 Debugging

PIN	Define	Designation
2	RXD	RS232 communication receiver
3	GND	Communication power grounding
5	TXD	RS232 communication sender

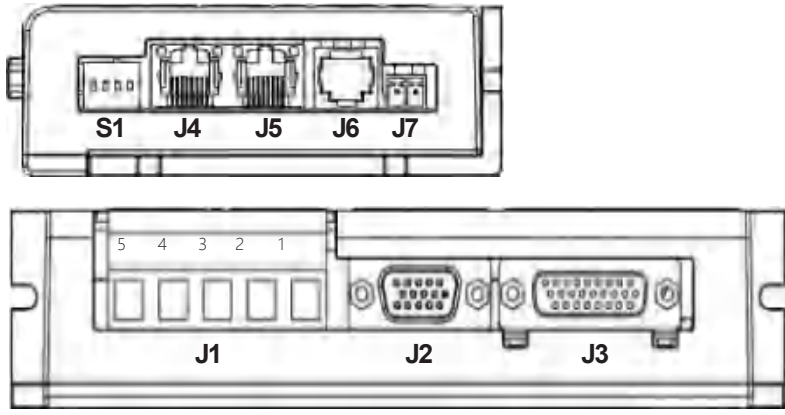

J1 Motor Power

NO.	Define	terminal	Wiring instructions
1	U	Motor power line U phase	Must be connected to the motor one by one according to the label
2	V	Motor power line V phase	
3	W	Motor power line W phase	
4	GND	Input power -	+20~90V DC
5	+HV	Input power +	

J4-J5 CAN communication link

PIN	Define	Function
1	CAN_H	CANH signal
2	CAN_L	CANL signal
3	GND	Communication power ground

J7 Auxiliary power supply

GND	0V
+AUXHV	+24V (or ≤ mains voltage)

J3 Control signal terminal

PIN	Define	Function	PIN	Define	Function
1	ISO_COM	Common end of ISO terminal	14	OUT1	custom
2	Ref-	Analog quantity - input	15	OUT2	custom
3	Ref+	Analog quantity + input	16	OUT3	custom
4	IN1	custom	17	MUL_ENC_S-	Second absolute value encoding input
5	IN2	custom	18	MUL_ENC_S+	Second absolute value encoding input
6	IN3	custom	19	GND	Power grounding
7	IN4	custom	20	+5V	5V power output (100mA)
8	IN5	custom	21	EONZ-(CLK-/MA-)	Motor encoder output signal Z- (or second absolute value encoder input)
9	IN6	custom	22	EONZ+(CLK+/MA+)	Motor encoder output signal Z+ (or second absolute value encoder input)
10	ISO_IN7	custom	23	EONB-	Motor encoder output signal B-
11	ISO_IN8	custom	24	EONB+	Motor encoder output signal B+
12	ISO_IN9	custom	25	EONA-	Motor encoder output signal A-
13	ISO_IN10	custom	26	EONA+	Motor encoder output signal A+

DE Series outline dimension drawing

J2 Motor encoder feedback

PIN	Define	Function	PIN	Define	Function
1			9	W+	Motor encoder W+ input
2			10		
3	U+	Motor encoder U+ input	11	B-(DAT-)	Motor encoder B- input (Absolute value coder DAT-)
4	+5V	Motor signal line +5V	12	B+(DAT+)	Motor encoder B+ input (Absolute encoder DAT+)
5	0V	Motor signal cable GND	13	A-	Motor encoder A- input
6	V+	Motor encoder V+ input	14	A+	Motor encoder A+ input
7	Z- (CLK-/MA-)	Motor encoder Z- input (Absolute value CLK-/MA-)	15		
8	Z+ (CLK+/MA+)	Motor encoder Z+ input (Absolute value CLK-/MA-)			

SW Indicates the station number of the DIP switch

SW switch Number	Corresponding stand no
1	1
2	2
3	4
4	8

DE Series External Dimensions

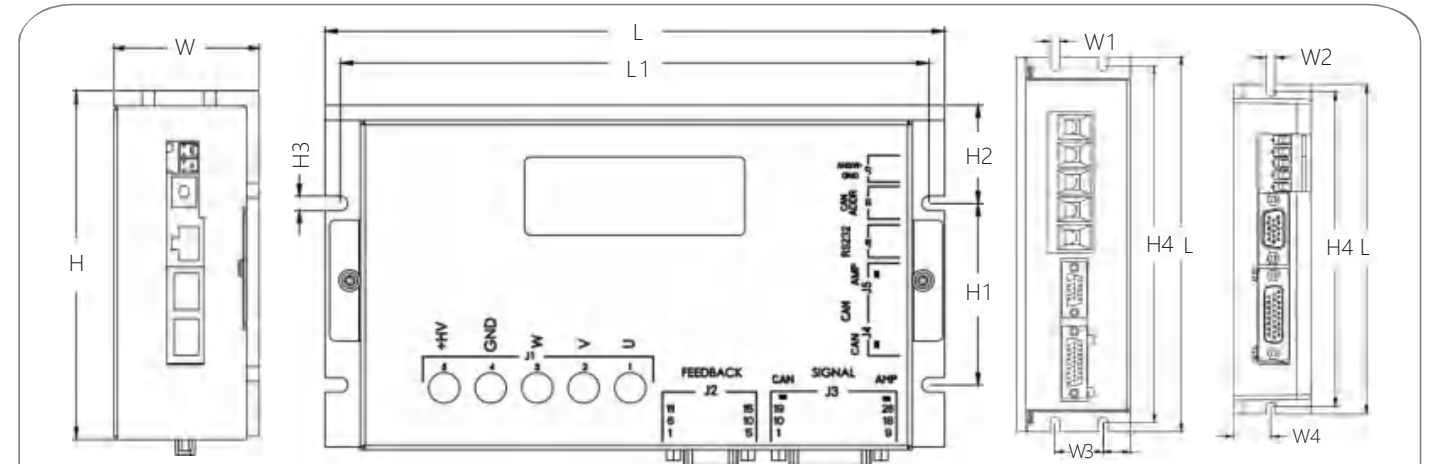

Model	L	L1	W	W1	W2	W3	W4	H	H1	H2	H3	H4
DEPC-3A~50A	167	160	35	/	2-4.5	/	19.5	100	51	22	4-4.5	160
DEPC-75A	200	190	59	4-5.0	/	25	/	114	60	32.5	4-4.8	190
DEPC-100A	200	190	59	4-5.0	/	25	/	114	60	32.5	4-4.8	190
DEPC-150A	221	211	59	5	/	25	/	140	60	45	4.8	211
DEPC-200A	221	211	85	5	/	25	/	140	/	/	/	211
DEPC-300A	221	211	85	5	/	25	/	140	/	/	/	211

DE2 Series Technical Specifications

- ◆ Control mode: position, speed, torque;
- ◆ Sampling frequency (time) Current loop: 16KHz(62.5us); Speed/Position Loop :4KHz(250μs);
- ◆ Bandwidth: the current loop is generally 2.5kHz, which varies with parameter adjustment and load inductance;
- ◆ Programmable protection: position error, over current, over voltage or under voltage, I²t, output short circuit overload and other multi-directional protection functions;
- ◆ Driving motor type: brushless motor, brush motor, linear motor, voice coil motor, etc;
- ◆ Encoder feedback: incremental encoder, Hall, grating scale, analog sine and cosine (Sin/Cos) encoder, rotary transformer (plus conversion card), Absolute encoder, support SSI, Absolute A, BiSS(B&C) protocol;
- ◆ Pulse response frequency up to 2MHz, with digital filtering function;
- ◆ RS232 serial interface, baud rate up to 115KB;
- ◆ CAN2.0 local area bus, compatible with CANopen DS-402, baud rate up to 1MHz; Support PVT, back to zero, interpolation;
- ◆ EtherCAT Ethernet Fieldbus, used as EtherCAT slave using CANopen application protocol, supports cyclic synchronous position-speed-Torque (CSP-CSV-CST),PVT, interpolation, and zero back for DSP-402 motion control devices with EtherCAT(CoE) protocol;
- ◆ Power supply voltage: 20-90(135/180)VDC;



Position control	Command control mode		Pulse, ±10V analog input, CANopen (EtherCAT), function generator, track index, software programming.	
	Input signal	Pulse instruction	Input pulse pattern	The command can be direction + pulse, ORTHOGONAL pulse of A and B phases, and CW/CCW pulse.
Signal format			Collector open circuit	
Maximum pulse frequency			Biggest 2 MPPS	
Analog instruction		Voltage range	Input voltage range ±10V	
		Input impedance	Differential input impedance=5KΩ	
Speed control	Command control mode		PWM, ±10V analog, function generator, software programming	
	Input signal	PWM	Polarity	PWM=0~100%, polarity=1/0
			Nonpolar	PWM=50% +/-50%
			Frequency range	Minimum 1 kHz, maximum 100 kHz
		Minimum pulse width	220ns	
	Analog instruction	Voltage range	Input voltage range ±10V	
		Input impedance	Differential input impedance=5KΩ	
Current control	Command control mode		PWM, ±10V analog, function generator, software programming	
	Input signal	PWM	Polarity	PWM=0~100%, polarity=1/0
			Nonpolar	PWM=50% +/-50%
			Frequency range	Minimum 1 kHz, maximum 100 kHz
		Minimum pulse width	220ns	
	Analog instruction	Voltage range	Input voltage range ±10V	
		Input impedance	Differential input impedance=5KΩ	
I/O signal	Digital input IN		Number of Ports	16 (IN3, IN4, IN11 and IN12 are high-speed ports)
			Signal format	NPN, PNP
	Digital output OUT		Settable function	Servo enable, external reset, positive/reverse limit, motor stop, high speed analog acquisition control, PWM synchronous signal input, high speed pulse input, etc.
			Number of Ports	6
		Signal format	Optocoupler output, maximum voltage 30Vdc. Two special motor lock output	
		Settable function	Fault signal, brake control, PWM sync signal, custom event, track state, position trigger, program control.	

Function	LED indicator		State indicator, CAN (EtherCAT) network indicator	
	Communications functions	RS-232	Baud rate	9600-115200
			Agreement	Full duplex mode, ASCII or binary format
		CAN	Baud rate	20kbit/s-1Mbit/s
Agreement	Canopen application layer DS-301V4.02			
		Equipment	Dsp-402 device driver and motion control	
	EtherCAT	Agreement	CoE, CiA-402	
Use environment	Protection function		Overvoltage, overcurrent, undervoltage, overload, overheating, abnormal encoder, too large position tracking error and other protection.	
	Installation location		Non-corrosive gas, flammable gas, etc	
	Altitude		Below 1000 m	
	Temperature		-20°C~+50°C	
	Humidity		5%~95%RH, No condensation of water droplets	
	Resistance to vibration/impact		Less than 4.9m/s ² / less than 19.6m/s ²	
Feedback	Digital A/B quadrature encoder (-E, max. 5M line/s)			
	Auxiliary encoder input/output (full closed-loop control/-OP)			
	Analogue sin/cos encoder (-S) optional			
	Rotary Transformer(-R) Optional			
	Digital Hall (-H (U/V/W, 120 degrees electrical phase difference)			
Absolute encoder (A17) optional				

DE2 Typical wiring diagram

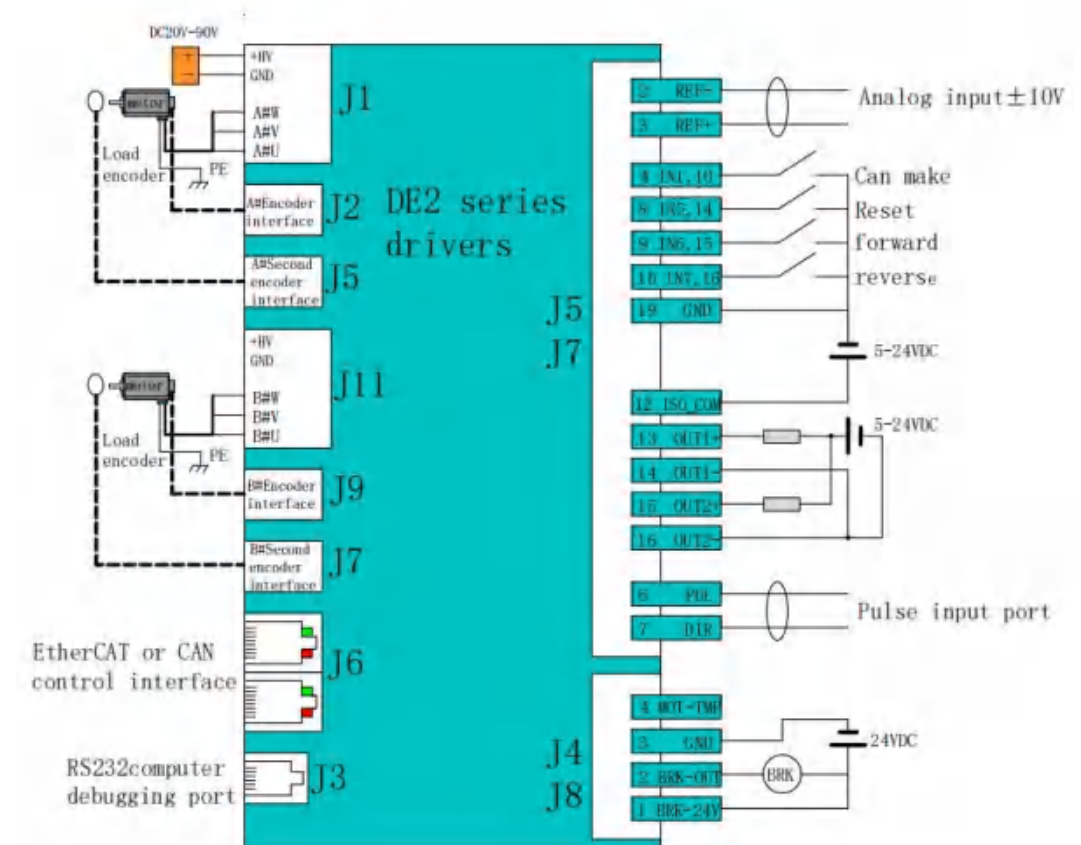

DE2 Series Terminal Definition

DE2 Series Terminal Definition

J3 RS-232 Debugging

PIN	Define	Designation
2	RXD	RS232 communication receiver
3	GND	Communication power grounding
5	TXD	RS232 communication sender

J1 & J11 Motor Power

NO.	Define	terminal	Wiring instructions
1	A#U	Motor power line U phase	Must be connected to the motor one by one according to the label
2	A#V	Motor power line V phase	
3	A#W	Motor power line W phase	
4	GND	Input power -	+20~90V DC
5	+HV	Input power +	

J5(A#) & J7(B#) Control signal terminal

PIN	Define	Function	PIN	Define	Function
1	FG	grounding	14	ISO_OUT1-	custom
2	Ref-	Analog quantity - input	15	ISO_OUT2+	custom
3	Ref+	Analog quantity + input	16	ISO_OUT2-	custom
4	A#_IN1 B#_IN10	custom	17	MUL_ENC_S-	Second absolute value encoding input
5	A#_IN2 B#_IN11	custom	18	MUL_ENC_S+	Second absolute value encoding input
6	A#_IN3 B#_IN12	custom	19	GND	Power grounding
7	A#_IN4 B#_IN13	custom	20	+5V	5V power output (100mA)
8	A#ISO_IN5 B#ISO_IN14	custom	21	EONZ- (CLK-/MA-)	Motor encoder output signal Z- (or second absolute value encoder input)
9	A#ISO_IN6 B#ISO_IN15	custom	22	EONZ+ (CLK+/MA+)	Motor encoder output signal Z+ (or second absolute value encoder input)
10	A#ISO_IN7 B#ISO_IN16	custom	23	EONB-	Motor encoder output signal B- (or second incremental encoder input)
11	A#ISO_IN8 B#ISO_IN17	custom	24	EONB+	Motor encoder output signal B+ (or second incremental encoder input)
12	ISO_COM	Common end of ISO terminal	25	EONA-	Motor encoder output signal A- (or second incremental encoder input)
13	ISO_OUT1+	custom	26	EONA+	Motor encoder output signal A+ (or second incremental encoder input)

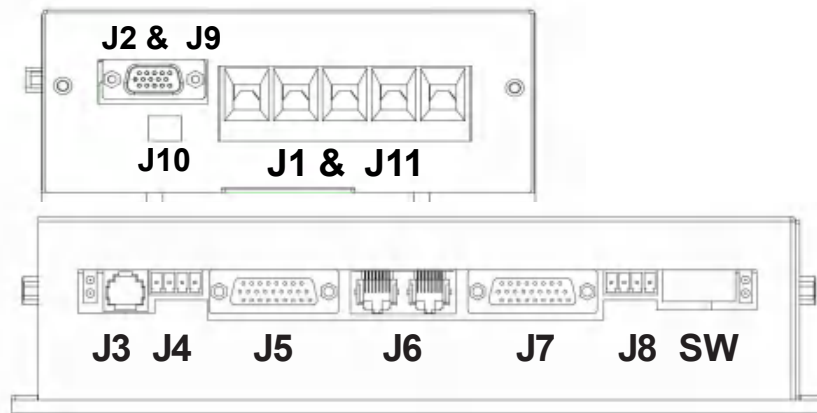

J6 CAN communication link

PIN	Define	Function
1	CAN_H	CANH signal
2	CAN_L	CANL signal
3/7	GND	Communication power ground

J10 Auxiliary power supply

Define	Function
GND	0V
+AUXHV	+24V (or ≤ mains voltage)

DE2 Series outline dimension drawing

Motor encoder feedback J2(A#) & J9(B#)

Pin	Define	Function	Pin	Define	Function
1	SIN+	SIN+	9	W+	Motor encoder W+ input
2	SIN-	SIN-	10	COS+	COS+
3	U+	Motor encoder U+ input	11	B-(DAT-)	Motor encoder B- input (Absolute value coder DAT-)
4	+5V	Motor signal line +5V	12	B+(DAT+)	Motor encoder B+ input (Absolute encoder DAT+)
5	0V	Motor signal cable GND	13	A-	Motor encoder A- input
6	V+	Motor encoder V+ input	14	A+	Motor encoder A+ input
7	Z- (CLK-/MA-)	Motor encoder Z- input (Absolute value CLK-/MA-)	15	COS-	COS-
8	Z+ (CLK+/MA+)	Motor encoder Z+ input (Absolute value CLK-/MA-)			

SW Indicates the station number of the DIP switch

SW switch Number	Corresponding stand no.	SW switch Number	Corresponding stand no.
1	1	5	16
2	2	6	32
3	4	7	64
4	8	8	128

J4(A#) & J8(B#) Control Motor Brake Enable Terminal

NO.	Define	Function
1	BRK-24	External 24V
2	BRK-OUT	Brake output
3	GND	External 0V
4	MOT-TMP	Motor temperature switch

DE2 Series External Dimensions

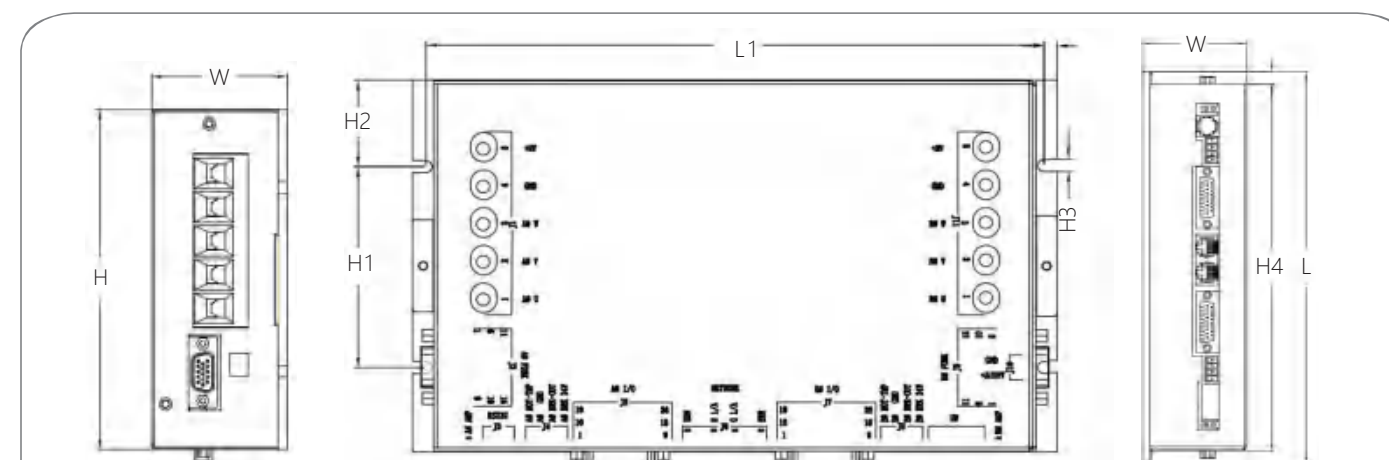

Model	L	L1	W	H	H1	H2	H3	H4
DE2PC-09003A~50A	208	198	40	118	101	/	4-4.8	192
DE2PC-09075A~150A	245	235	59	148	80	34.5	4-5.0	229
DE2PC-18024A	208	198	40	118	101	/	4-4.8	192
DE2PC-18050A~75A	245	235	59	148	80	34.5	4-5.0	229
DE2PC-135100A								

BC Series Technical Specifications

BC Series Technical Specifications

- ◆ Control mode: position, speed, torque;
- ◆ Sampling frequency (time) Current loop: 16KHz (62.5us) ;Velocity/position loop: 2KHz (500μs)
- ◆ Programmable protection: position error, over current, over voltage or under voltage, I²t, output short circuit, overload and other multi-directional protection functions;
- ◆ Drive motor type: brushless motor, servo motor, wheel motor;
- ◆ Position feedback: incremental encoder, digital Hall feedback; Absolute encoder Tama Agawa protocol;rotary transformer (external conversion card).
- ◆ Pulse response frequency up to 2MHz, with digital filtering function.
- ◆ Communication mode:
 1. RS232 serial interface, baud rate up to 115KB;
 2. RS485 MODBUS RTU serial interface, baud rate up to 115KB;
 3. CAN communication, compatible with CANopen DS-402, baud rate up to 1MHz ; PVT, zero return, interpolation ; (Only one RS485 or CAN can be selected)
- ◆ Power supply voltage: 18-90(135/180)VDC;



Position control	Command control mode		Pulse, ±10V analogue, CANopen, RS485 MODBUS RTU		
	Input signal	Pulse instruction	Input pulse pattern	Includes "direction + pulse", "A, B phase orthogonal pulse", "CW/CCW pulse" three command forms.	
Signal format			Open collector		
Maximum pulse frequency		Open collector: (Max. 500Kpps)			
Analog instruction		Voltage range	Input voltage range ±10V		
	Input impedance	Differential input impedance=5KΩ			
Speed control	Command control mode		PWM、RC model aircraft signal、±10V analogue、CANopen、RS485 MODBUS RTU		
	Input signal	PWM	Polarity	PWM=0~100%, polarity=1/0	
			Nonpolar	PWM=50% +/-50%,	
			Frequency range	Minimum 1 kHz, maximum 100 kHz	
			Minimum pulse width	220ns	
	Analog instruction	Voltage range	Input voltage range ±10V		
Input impedance		Differential input impedance=5KΩ			
Current control	Command control mode		±10V analogue、CANopen、RS485 MODBUS RTU		
	Input signal	PWM	Polarity	PWM=0~100%, polarity=1/0	
			Nonpolar	PWM=50% +/-50%,	
			Frequency range	Minimum 1 kHz, maximum 100 kHz	
			Minimum pulse width	220ns	
	Analog instruction	Voltage range	Input voltage range ±10V		
Input impedance		Differential input impedance=5KΩ			
I/O signal	Digital input IN		Number of Ports	12 (IN6, IN7, IN8, IN9, IN10 are high-speed ports, maximum voltage 12V), other input ports maximum input voltage 24V.	
			Signal format	NPN,PNP (The software setup input is NPN or PNP)	
	Digital output OUT		Settable function	Servo enable, external reset, forward/reverse limit, motor stop, high-speed pulse input, etc.	
			Number of Ports	3	
			Signal format	NPN (low level effective), can withstand the maximum current 300mABC, the maximum voltage 30VBC	
			Settable function	Fault signal, lock control	

BC Series Technical Specifications

Function	LED indicator		Drive status indication, communication indication		
	Communications functions	RS-232	Baud rate	9600-115200	
			Agreement	Full duplex mode, ASCII or binary format	
		RS-485	Baud rate	9600-115200	
			Agreement	modbus RTU	
		CAN	Baud rate	20kbit/s-1Mbit/s	
Agreement			Canopen application layer DS-301V4.02		
Equipment	Dsp-402 device driver and motion control				
Use environment	Protection function		Over-voltage,over-current,under-voltage,overload,overheat, encoder abnormality, position tracking error, etc. protection		
	Installation location		Non-corrosive gas, flammable gas, etc		
	Altitude		Below 1000 m		
	Temperature		-20°C~+50°C		
	Humidity		5%~95%RH, No condensation of water droplets		
Feedback	Resistance to vibration/impact		Less than 4.9m/s ² / less than 19.6m/s ²		
	Digital A/B quadrature encoder (-E, max. 5M line/s)				
	Auxiliary encoder input/output (full closed-loop control/-OP)				
	Rotary Transformer(-R) Optional				
	Digital Hall (-H (U/V/W, 120 degrees electrical phase difference))				
Absolute encoder (A17) optional					

BC Typical wiring diagram

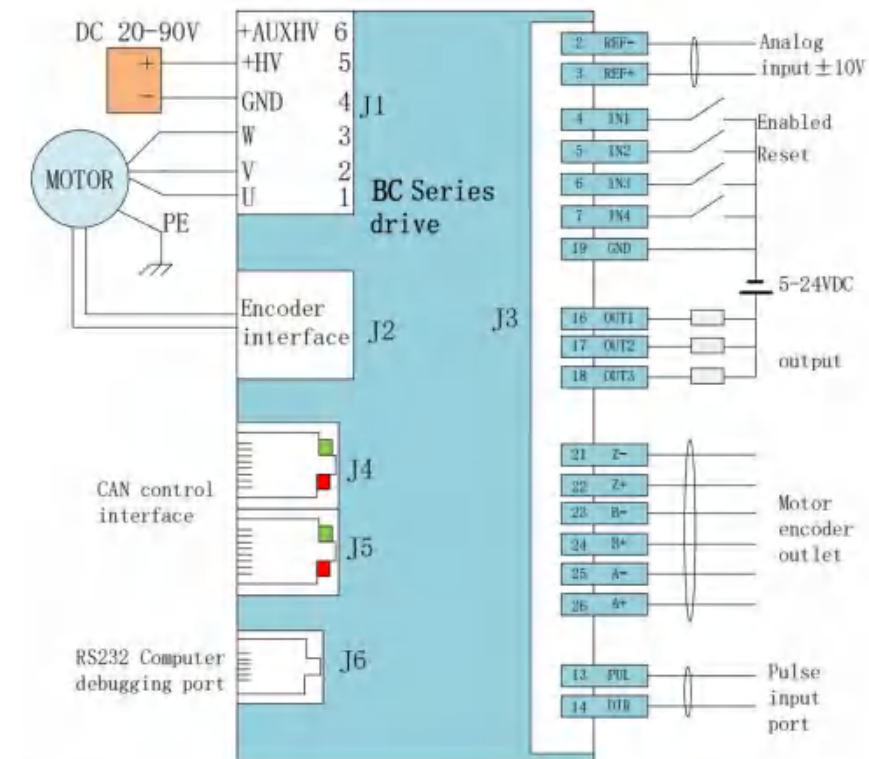

Description:

1. Input terminals IN1,IN2,IN3,IN4,IN5,IN 11,IN12 are common ports that can receive NPN and PNP signals. The maximum input voltage is 24V;
2. IN6, IN7,IN8,IN9,IN10 are high-speed input ports with the highest input voltage of 5V;
3. AUXHV is an auxiliary power supply, which can be connected if necessary. If connected, communication is maintained when +HV is disconnected and +AUXHV is powered on, but there is no action when issuing commands.

BC Series Terminal Definition

J6 RS-232 Debugging

PIN	Define
1	NO Connection
2	RXD
3	Signal Ground
4	Signal Groudh
5	TXD
6	NO Connection

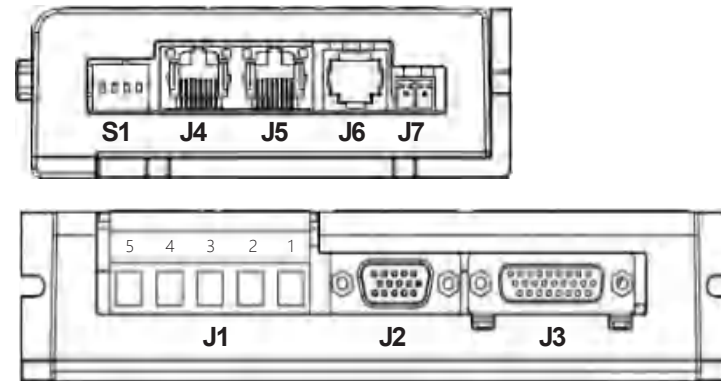

J4-J5 CAN (RS485)communication terminal

PIN	Define	Optional
1	485A (CAN_H)	Optional CAN communication function in parentheses
2	485A (CAN_H)	
3	GND_C	
4	GND_C	
5	485B (CAN_L)	
6	485B (CAN_L)	

J1 Motor Power

PIN	Define
1	U
2	V
3	W
4	0V
5	DC20-90V

J7 Auxiliary power supply

GND	0V
+AUXHV	+24V (or ≤ mains voltage)

J3 Control signal terminal

PIN	Define	PIN	Define	PIN	Define
1	Grounding	10	[IN6] custom	19	0V
2	Analog quantity - input	11	[IN7] custom	20	+5V
3	Analog quantity + input	12	[IN8] custom	21	Motor encoder Z- input
4	[IN1] Enable	13	[IN9] custom	22	Motor encoder Z+ input
5	[IN2] custom	14	[IN10] custom	23	Motor encoder B- input
6	[IN3] custom	15	[IN5] Motor temperature	24	Motor encoder B+ input
7	[IN4] custom	16	[OUT1] custom	25	Motor encoder A- input
8	[IN11] custom	17	[OUT2] custom	26	Motor encoder A+ input
9	[IN12] custom	18	[OUT3] custom		

J2 Motor encoder feedback

PIN	Define	PIN	Define	PIN	Define
1	NTC*	6	V+	11	B-(Absolute DAT-)
2	NTC*	7	Z-	12	B+ (Absolute DAT+)
3	U+	8	Z+	13	A-
4	+5 V	9	W+	14	A+
5	0V	10		15	IN5* Temperature control switche

Note: 1. For hub motor, if the encoder input signal is single-ended open-collector signal, A connects to pin 13 and B connects to pin 11;
 2. *If you need Need NTC resistance temperature sensor input function, order please indicate;
 3. *If the temperature switch sensor input function is required, connect to pin 1 and pin 15, order please indicate.

SW Indicates the station number of the DIP switch

SW switch Number	Corresponding stand no
1	1
2	2
3	4
4	8

BC Series External Dimensions

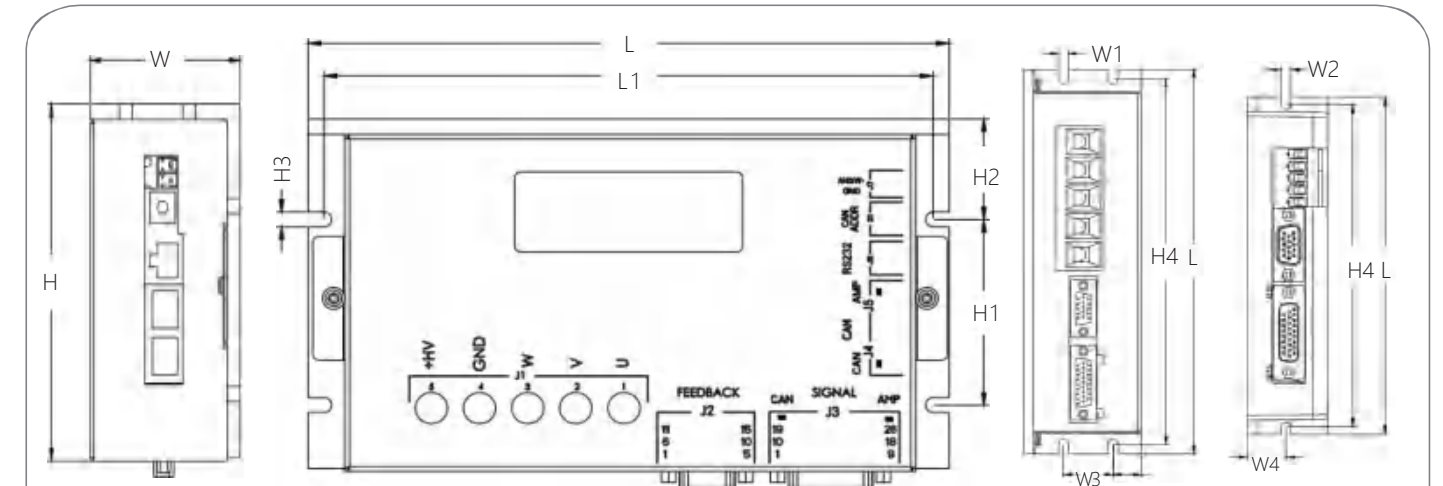

Model	L	L1	W	W1	W2	W3	W4	H	H1	H2	H3	H4
BCPC-02~15A	141	134	32	/	4.5	/	15.5	90	51	18	4.5	134
BCPC-20A~35A	167	160	35	/	2-4.5	/	19.5	100	51	22	4-4.5	160
BCPC-50A~85A	200	190	59	4-5.0	/	25	/	114	60	32.5	4-4.8	190
BCPC-100A	221	211	59	5	/	25	/	140	60	45	4.8	211
BCPC-140A210A	221	211	85	5	/	25	/	140	/	/	/	211
BCPC-250A	265	255	85	5	/	25	/	140	/	/	/	211

BC2 Series Technical Specifications

- ◆ Control mode: position, speed, torque;
- ◆ Sampling frequency (time) Current loop: 16KHz(62.5us); Speed/position loop :2KHz(500μs);
- ◆ Bandwidth: The current loop is generally 1.5kHz, which varies with parameter adjustment and load inductance;
- ◆ Programmable protection: position error, over current, over voltage or under voltage, I²t, output short circuit, overload and other multi-directional protection functions;
- ◆ Drive motor type: DC brushless motor, hollow cup brushless motor, wheel hub motor, DC servo motor;
- ◆ Encoder feedback: incremental encoder, Digital Hall, grating ruler, rotary transformer (plus converter card), absolute encoder (Tama Kawa Protocol);
- ◆ Pulse response frequency up to 2MHz, with digital filtering function;
- ◆ RS232 serial interface, baud rate up to 115KB;
- ◆ CAN communication, compatible with CANopen DS-402, baud rate up to 1MHz: PVT, zero return, interpolation ;
- ◆ RS485 MODBUS RTU serial interface, baud rate up to 115KB
(Only one RS485 or CAN can be selected);
- ◆ Power supply voltage: 18-90(135/180)VDC.



Position control	Command control mode			Pulse、CANopen、RS485 MODBUS RTU
	Input signal	Pulse instruction	Input pulse pattern	Includes "direction + pulse", "A, B phase orthogonal pulse", "CW/CCW pulse" three command forms.
			Signal format	Open collector
		Maximum pulse frequency	Maximum is 2Mpps	
Speed control	Command control mode			PWM(RC command)、±10V analogue、CANopen、RS485 MODBUS RTU
	Input signal	PWM (RC command)	polarity	PWM=0~100%, polarity=1/0
			nonpolar	PWM=50% +/-50%,
			Frequency range	Minimum 1 kHz, maximum 100 kHz
	Minimum pulse width	220ns		
	Input signal	Analog instruction	Voltage range	Input voltage range ±10V
			impedance	Differential input impedance =5KΩ
Current control	Command control mode			PWM、±10V analogue、CANopen、RS485 MODBUS RTU
	Input signal	PWM	polarity	PWM=0~100%, polarity=1/0
			nonpolar	PWM=50% +/-50%,
			Frequency range	Minimum 1 kHz, maximum 100 kHz
	Minimum pulse width	220ns		
	Input signal	Analog instruction	Voltage range	Input voltage range ±10V
			impedance	Differential input impedance =5KΩ
I/O signal	Digital input IN		Number of Ports	10 (IN4, IN5, IN9, IN10 are high-speed ports)
			Signal format	NPN, PNP
			Settable function	Servo enable, external reset, forward/reverse limit, motor stop, high-speed pulse input, etc.
	Digital output OUT		Number of Ports	6
			Signal format	NPN (low level active), can withstand maximum current 2A, maximum voltage 30V DC
Settable function			Fault signal, lock control	

Function	LED indicator		Drive status indication, communication indication	
	Communications functions	RS-232	Baud rate	9600-115200
			Agreement	Full duplex mode, ASCII or binary format
		RS-485	Baud rate	9600-115200
			Agreement	modbus RTU
CAN	Baud rate	20kbit/s-1Mbit/s		
	Agreement	Canopen application layer DS-301V4.02		
	Equipment	Dsp-402 device driver and motion control		
Protection function		Over-voltage, over-current, under-voltage, overload, overheat, encoder abnormality, position tracking error, etc. protection		
Use environment	Installation location		Non-corrosive gas, flammable gas, etc	
	Altitude		Below 1000 m	
	Temperature		-20°C~+50°C	
	Humidity		5%~95%RH, No condensation of water droplets	
	Resistance to vibration/impact		Less than 4.9m/s ² / less than 19.6m/s ²	
Feedback	Digital A/B quadrature encoder (-E, max. 5M line/s)			
	Rotary Transformer(-R) (external resolution card),Optional			
	Digital Hall (-H (U/V/W, 120 degrees electrical phase difference)			
	Absolute encoder (A17) optional			

BC2 Typical wiring diagram

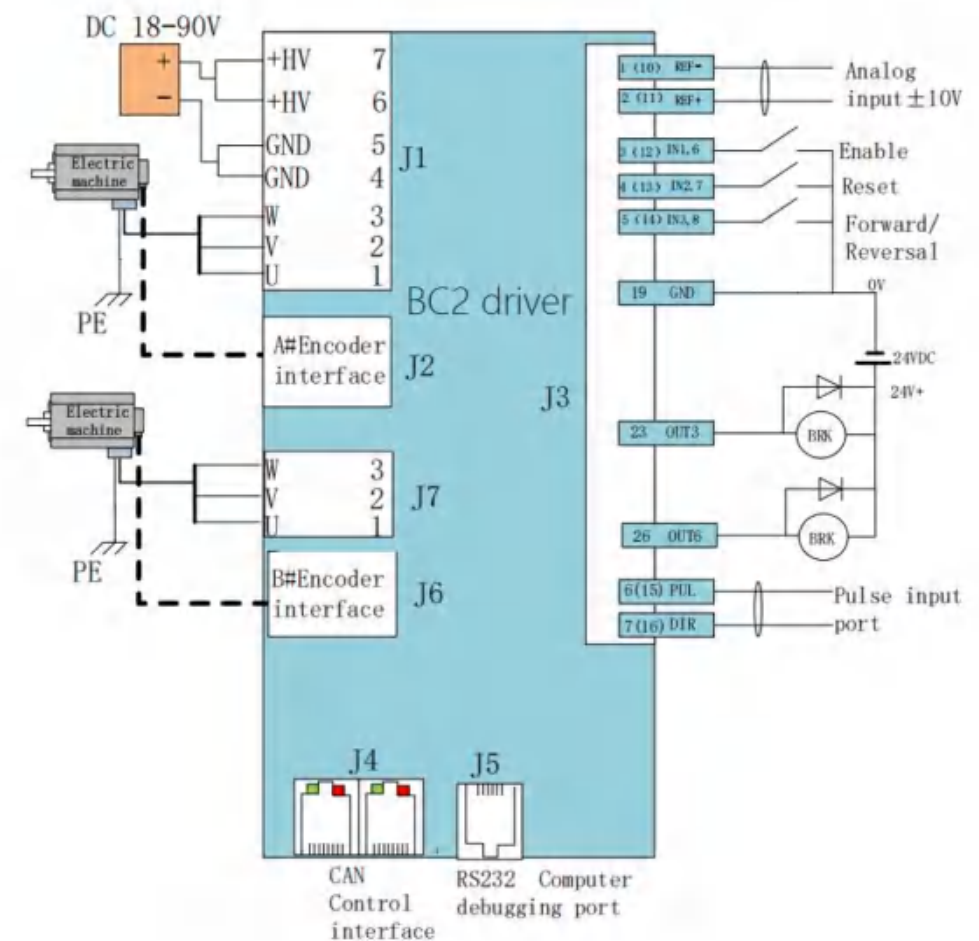

BC2 Series Terminal Definition

J5 RS-232 Debugging

PIN	Define	Designation
2	RXD	RS232 communication receiver
3	GND	Communication power grounding
5	TXD	RS232 communication sender

SW dialling code corresponds to station number

SW switch number	Corresponding station number
1	1
2	2
3	4
4	8

J1A # Motor Power

NO.	Define	Terminal	Wiring instructions
1	A#U	Motor power line U phase	Must be connected to the motor one by one according to the label
2	A#V	Motor power line V phase	
3	A#W	Motor power line W phase	
4\5	GND	Input power -	+18~90(135/180)VDC
6\7	+HV	Input power +	

J7B # Motor

NO.	Define	Terminal	Wiring instructions
1	B#U	Motor power line U phase	Must be connected to the motor one by one according to the label
2	B#V	Motor power line V phase	
3	B#W	Motor power line W phase	

Motor encoder feedback J2 & J6

Pin	Define	Function	Pin	Define	Function
1	NTC*	NTC resistance temperature sensor wiring (Analog input function 2 select 1)	9	W+	Motor encoder W+ input
2	NTC*		10		
3	U+	Motor encoder U+ input	11	B-(DAT-)	Motor encoder B input (Absolute value coder DAT-)
4	+5V	Motor signal line +5V	12	B+(DAT+)	Motor encoder B+ input (Absolute value coder DAT+)
5	0V	Motor signal cable GND	13	A-	Motor encoder A- input
6	V+	Motor encoder V+ input	14	A+	Motor encoder A+ input
7	Z-	Motor encoder Z- input	15	IN3&IN8*	Temperature switch sensor wiring
8	Z+	Motor encoder Z+ input			

Note: 1. For hub motor, if the encoder input signal is single-ended open-collector signal, A connectsto pin 13 and B connects to pin 11;
 2. *If you need Need NTC resistance temperature sensor input function, order please indicate;
 3. *If the temperature switch sensor input function is required, connect to pin 1 and pin 15,order please indicate.

J8 Auxiliary power supply

GND	0V
+AUXHV	+24V(or ≤ mains voltage)

J4 RS-485(CAN) communication terminal

PIN	Define	Optional
1	485A (CAN_H)	Optional CAN communication function in parentheses
2	485A (CAN_H)	
3	GND_C	
4	GND_C	
5	485B (CAN_L)	
6	485B (CAN_L)	

J3 Control signal I/O terminal

Pin	Define	Function	Pin	Define	Function
19	0V	Power ground	20	5V	5V output (100mA)
A axis			B axis		
1	A#AREF+	Analog positive input	10	B#AREF+	Analog positive input
2	A#AREF-	Analog negative input	11	B#AREF-	Analog negative input
3	A#IN1_GP	Hardware enable	12	B#IN6_GP	Hardware enable
4	IN2_GP	custom	13	IN7_GP	custom
5	IN3_GP	custom	14	IN8_GP	custom
6	IN4_HS	custom	15	IN9_HS	custom
7	IN5_HS	custom	16	IN10_HS	custom
8	OUT1	custom	17	OUT4	custom
9	OUT2	custom	18	OUT5	custom
21	A#ENC_A	Motor encoder output signal A	24	B#ENC_A	Motor encoder output signal A
22	A#ENC_B	Motor encoder output signal B	25	B#ENC_B	Motor encoder output signal B
23	OUT3	custom	26	OUT6	custom

Note: Only incremental encoders can output motor encoder signals.

BC2 Series External Dimensions

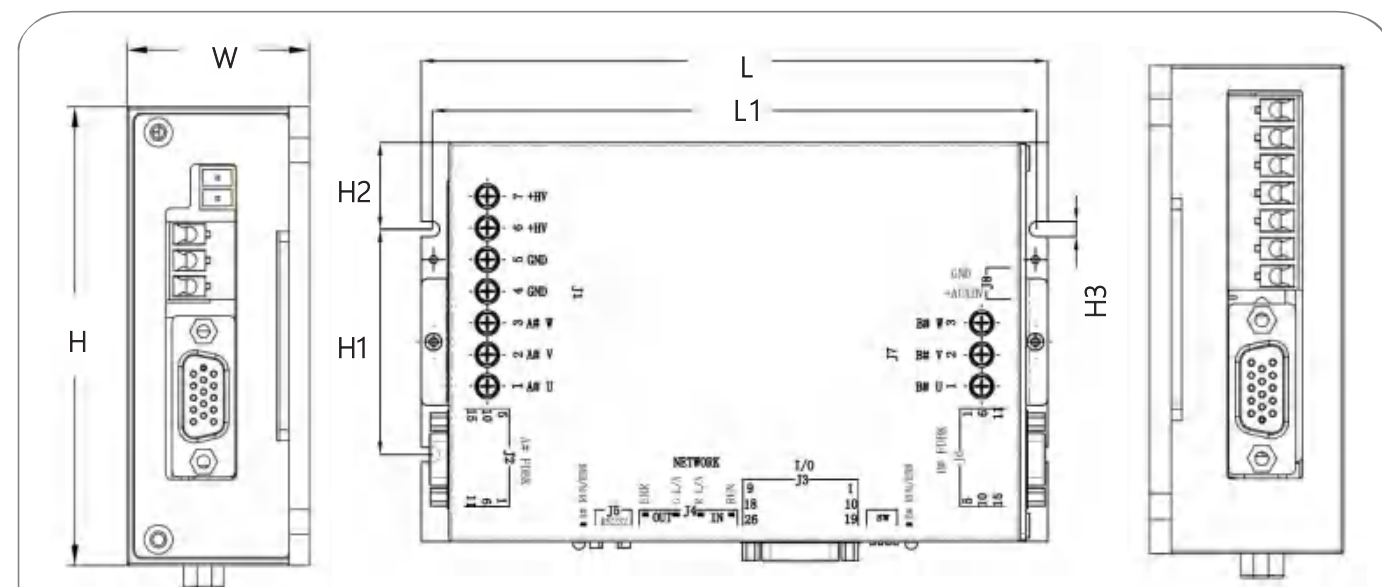

Model	L	L1	W	H	H1	H2	H3
BC2-01~25A	144	136.8	36	88	71.2	10.8	4.8
BC2-25A~35A	204	196.8	52	126	71.2	27.4	4.8
BC2-50A~70AF	204	196.8	86	130	71.2	29.4	4.8

DH DC Series Technical Specification

DH DC Series Technical Specifications

- ◆ Control mode: position, speed, torque;
- ◆ Sampling frequency (time) Current loop: 15KHz(66.7us); Speed/Position Loop :3KHz(330us);
- ◆ Motion mode: electronic gear, electronic CAM, proportional linkage, point to point;
- ◆ Programmable protection: position error, over current, over voltage or under voltage, I²t, output short circuit overload and other multi-directional protection;
- ◆ Type of driving motor: brushless motor, brush motor, linear motor, voice coil motor, etc;
- ◆ Position feedback: incremental encoder, Hall, grating ruler, analog sine and cosine (Sin/Cos) encoder(1.0Vp-p), rotary transformer (external conversion card);
- ◆ Pulse response frequency up to 2MHz, with digital filtering function;
- ◆ CAN2.0 local area bus, compatible with CANopen DS-402, baud rate up to 1MHz ;
- ◆ RS232 serial interface, baud rate up to 115KB;
- ◆ Power supply voltage: 300VDC/540VDC ;



Input voltage	160-390VDC ; 350-690VDC;
Input frequency	47-63Hz

Position control	Command control mode		Pulse, ±10V analogue input, CANopen, function generator Trace indexing, software programming	
	Input signal	Pulse instruction	Input pulse pattern	The command can be direction + pulse, ORTHOGONAL pulse of A and B phases, and CW/CCW pulse.
Signal format			Differential input, open collector	
Maximum pulse frequency			Differential input :(Max. 2Mpps); Open collector :(Max. 500Kpps)	
Analog instruction		Voltage range	Input voltage range ±10V	
	Input impedance	Differential input impedance=5KΩ		
Speed control	Command control mode		PWM, ±10V analog, function generator, software programming	
	Input signal	PWM	Polarity	PWM=0~100%, polarity=1/0
			Nonpolar	PWM=50% +/-50%
			Frequency range	Minimum 1kHz, maximum 100kHz
Analog instruction	Minimum pulse width	220ns		
	Voltage range	Input voltage range ±10V		
Input impedance			Differential input impedance=5KΩ	
	Current control	Command control mode		PWM, ±10V analog, function generator, software programming
Input signal		PWM	Polarity	PWM=0~100%, polarity=1/0
			Nonpolar	PWM=50% +/-50%
			Frequency range	Minimum 1kHz, maximum 100kHz
Analog instruction	Minimum pulse width	220ns		
	Voltage range	Input voltage range ±10V		
Input impedance			Differential input impedance=5KΩ	
	Digital input IN	Number of Ports		12(IN6, IN7, IN8, IN9 and IN10 are high-speed ports, IN5 is used for motor temperature protection)
Signal format		NPN(low active)		
Settable function		Servo enable, external reset, positive/reverse limit, motor running stop, high-speed analog acquisition control, PWM synchronous signal input, high-speed pulse input, etc		
Digital output OUT	Number of Ports		3	
	Signal format		NPN(low effective), can withstand a maximum current of 300mAdc, maximum voltage of 30Vdc	
	Settable function		Fault signal, brake control, PWM sync signal, custom event track state, position trigger, program control	

DH DC Series Technical Specification

Function	LED indicator		Drive status indication, communication indication	
	Communications functions	RS-232	Baud rate	9600-115200
			Agreement	Full duplex mode, ASCII or binary format
		CAN	Baud rate	20kbit/s-1Mbit/s
Agreement			Canopen application layer DS-301V4.02	
Equipment		Dsp-402 device driver and motion control		
Protection function		Overvoltage, overcurrent, undervoltage, overload, overheating, abnormal encoder, too large position tracking error and other protection		
Use environment	Installation location		Non-corrosive gas, flammable gas, etc	
	Altitude		Below 1000 m	
	Temperature		-20°C~+50°C	
	Humidity		5%~95%RH, No condensation of water droplets	
Resistance to vibration/impact		Less than 4.9m/s ² / less than 19.6m/s ²		
Feedback	Digital A/B quadrature encoder (-E, max. 5M line/s)			
	Auxiliary encoder input/output (full closed-loop control/-OP)			
	Analogue sin/cos encoder (-S) optional			
	Rotary Transformer(-R/external) Optional			
	Digital Hall (-H (U/V/W, 120 degrees electrical phase difference)			

DH DC Typical wiring diagram

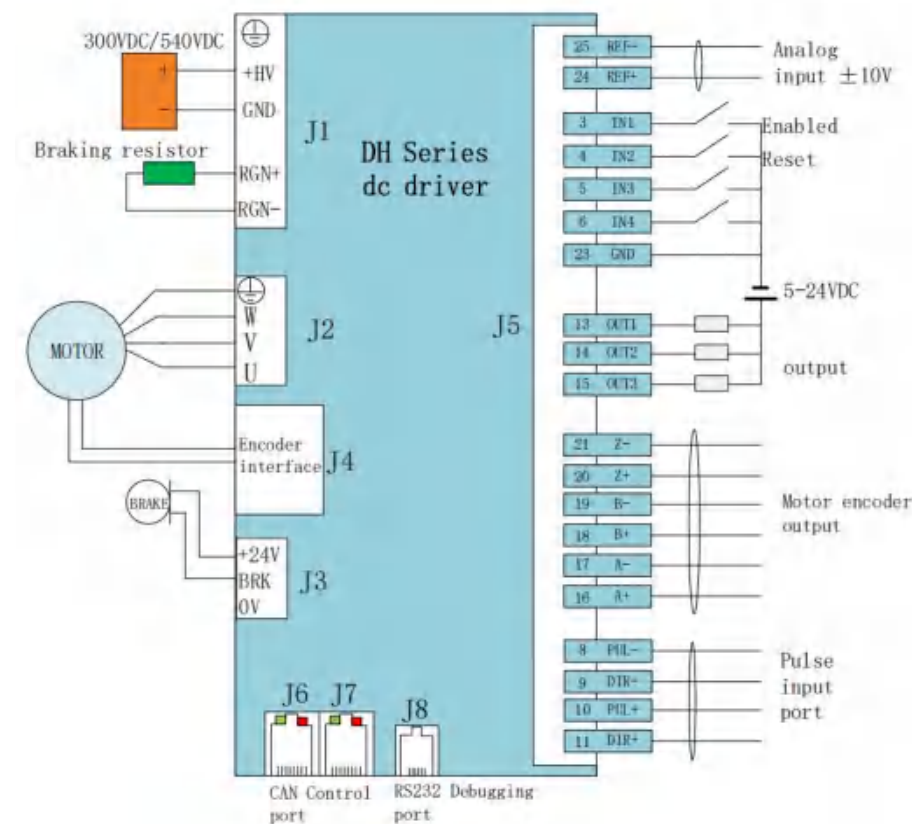

Description:

1. Input terminals IN1, IN2, IN3, IN4, IN5, IN 11, IN12 are common ports that can receive NPN and PNP signals. The maximum input voltage is 24V.
2. IN6, IN7, IN8, IN9, IN10 are high-speed input ports with the highest input voltage of 5V.

DH DC Series Terminal Definition

DH DC Series Terminal Definition

J1 Main power input terminal

PIN	Define	Designation
1	⊕	GND
2	GND	300VDC/540VDC
3	+HV	
4	RGN-	Brake Resistor Interface
5	RGN+	

J2 Motor Terminal

PIN	Define	Designation
1	⊕	Motor cable PE
2	W	Motor cable W
3	V	Motor cable V
4	U	Motor cable U

J6&J7 CAN communication link

PIN	Define	Designation
1	CANH	CANH signal
2	CANL	CANL signal
3/7	GND	Communication power grounding

J5 Control signal terminal

Pin	Define	Function	Pin	Define	Function
1	FG	Grounding	14	OUT2	custom
2	IN5	Motor temperature	15	OUT3	custom
3	IN1	Enable	16	EONA+	Motor encoder output signal A+
4	IN2	custom	17	EONA-	Motor encoder output signal A-
5	IN3	custom	18	EONB+	Motor encoder output signal B+
6	IN4	custom	19	EONB-	Motor encoder output signal B-
7	IN6	custom	20	EONZ+	Motor encoder output signal Z+
8	IN7	custom	21	EONZ-	Motor encoder output signal Z-
9	IN8	custom	22	+5V	5V power output(400mA)
10	IN9	custom	23	GND	power ground
11	IN10	custom	24	Ref+	Analog quantity + input
12	IN11	custom	25	Ref-	Analog quantity - input
13	OUT1	custom	26	IN12	custom

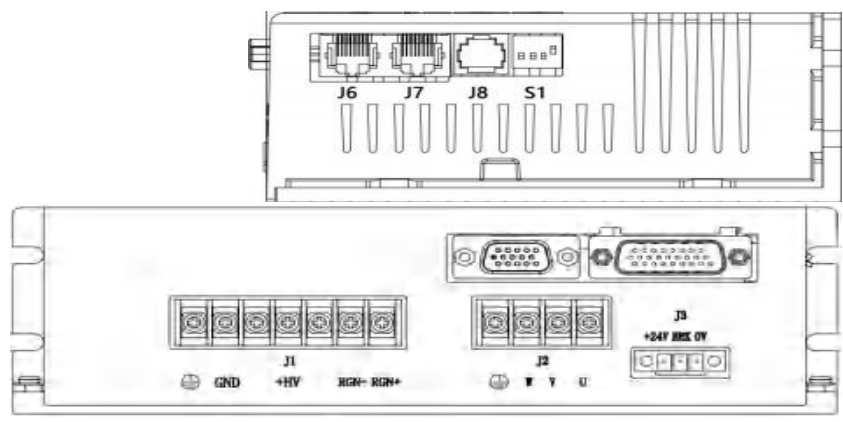

J3 Internal 24V output terminal (DC300V)

PIN	Define	Designation
1	+24v	24V output 200mA (Do not supply power to the motor lock)
2	BRK	Connect the motor holding wire
3	0V	0V

J3 External 24VDC input terminal (DC540V)

PIN	Define	Designation
1	+24v	External input ≥ 50W
2	BRK	Connect the motor holding wire
3	0V	0V

DH Series outline dimension drawing

J4 Motor encoder feedback

PIN	Define	PIN	Define	PIN	Define
1	A+	6	Z-	11	W+
2	A-	7	U+	12	SIN-
3	B+	8	SIN+	13	+5V
4	B-	9	V+	14	0V
5	Z+	10	COS+	15	COS-

J8 RS-232 Debugging

PIN	Define	Designation
2	RXD	RS232 communication receiver
3	GND	Communication power grounding
5	TXD	RS232 communication sender

S1 SW dial code switch station number

SW switch Number	Corresponding stand no
1	1
2	2
3	4
4	8

DH DC Series External Dimensions

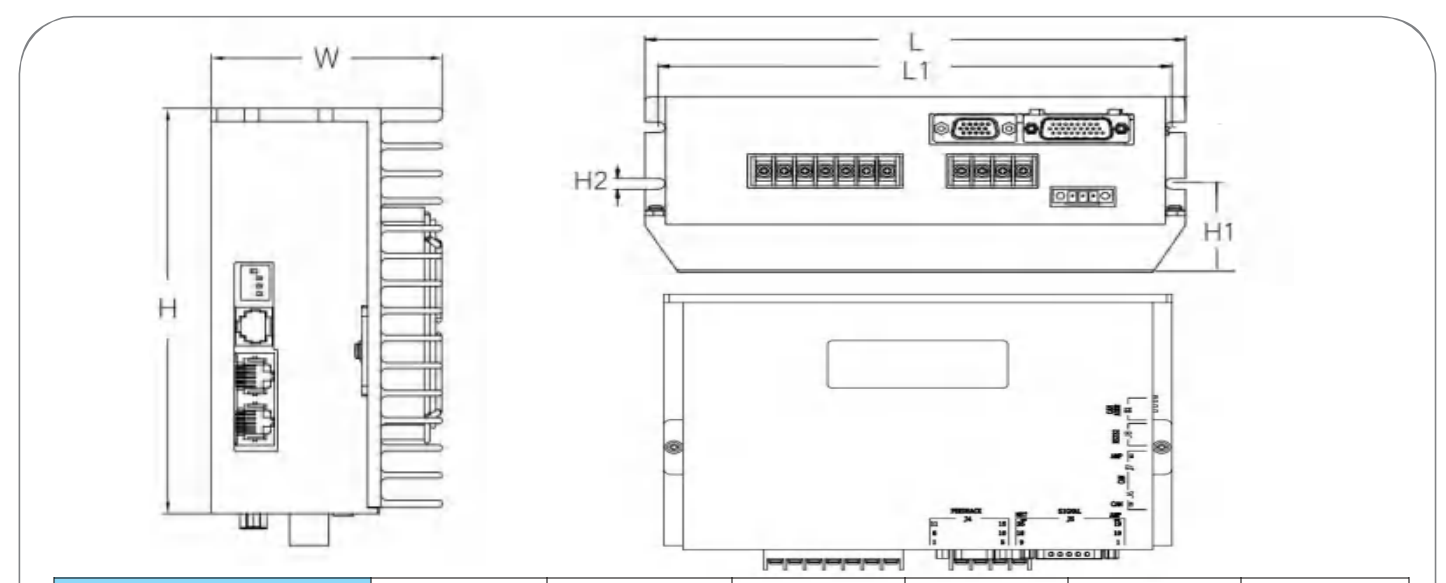

Model	L	L1	W	H	H1	H2
DHPC-30005-OPEB-DC	194	174	58.5	113.5	21	4-5.0
DHPC-30010-OPEB-DC						
DHPC-30015-OPEB-DC						
DHPC-54005-OPEB-DC	204	194	60	140	21	4-5.0
DHPC-30020-OPEB-DC						
DHPC-30025-OPEB-DC						
DHPC-54010-OPEB-DC	204	194	80	140	40.5	4-5.0
DHPC-54015-OPEB-DC						
DHPC-30035-OPEB-DC						
DHPC-30050-OPEB-DC	285	275	188	114	20.5	4-5.0
DHPC-54020-OPEB-DC						
DHPC-54025-OPEB-DC						
DHPC-54030-OPEB-DC						
DHPC-54035-OPEB-DC						

DC, DH DC, DE, DE2 and BC, BC2 Series Application Areas

Servo drive machine is used in various servo motors, robotics field, new energy field, automation field, AGV automotive industry, control system, can convert the input voltage signal into the mechanical output on the motor shaft, dragging the controlled element, so as to achieve the purpose of control.



Logistics automation



Robotics field



New energy field



Packaging machine field



Printing machine field



Product inspection system



AGV vehicle



Voice coil motor



Food processing



Textile machinery industry

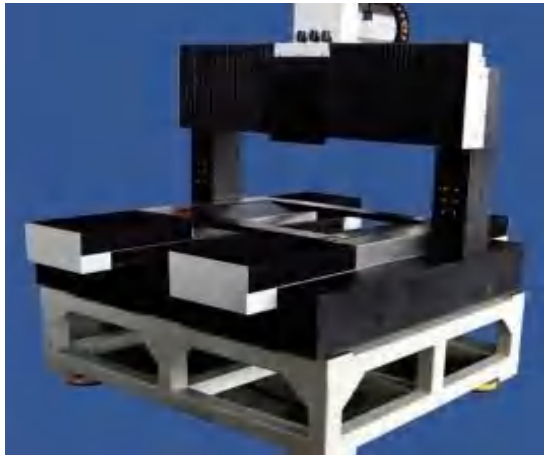

Linear motor



Rotary direct drive torque motor



Transportation system



Filling and marking



Spraying equipment industry

Drive Peripheral Accessories

Peripheral Accessories

DB-01-5P5 Brake unit



Product Overview:
 Principle of braking unit: The braking unit consists of a high-power transistor MOS and its driving circuit. Its function is to add an external braking component to speed up the consumption of regenerative power when the discharge current link capacitor cannot be stored within the specified voltage range or when the internal braking resistor cannot be consumed in time to make the DC part 'over-voltage'.

Model Summary:

Model	Input voltage	Power
DB-01-5P5	18-90VDC	0-5.5kW
DB-05-5P5	18-180VDC	0-5.5kW

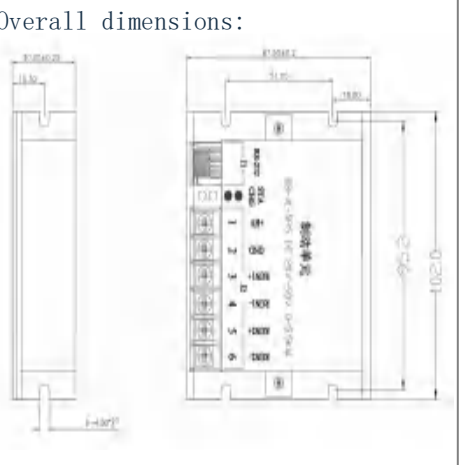

Resistive



Product Overview:
 Brake resistance: is a kind of aluminum shell resistance, mainly used in the mechanical system of the servo drive control motor to stop quickly, to help the motor convert the regenerative electric energy generated by the rapid stop into heat energy.

Model Summary:

Model	Power	Resistance value
300W 2R	300W	2R
300W 4R	300W	4R
300W 8R	300W	8R
600W 2R	600W	2R
600W 4R	600W	4R
1000W 4R	1000W	4R

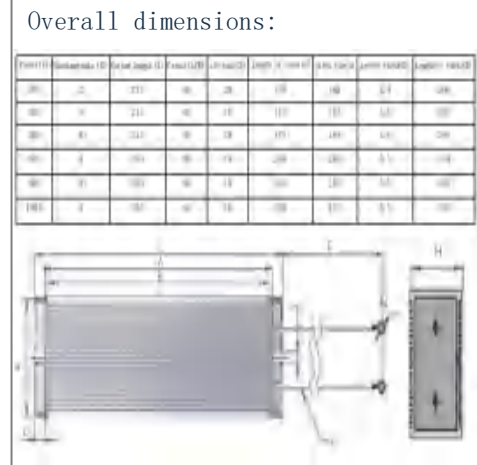

RS10-1003I Rotary card



Product Overview:
 The rotary decoding board is mainly used for rotary decoding, supporting incremental signal resolution modification, supporting 256, 1024, 4096, 16384 line 4-file resolution signal format; The rotary signal can also be converted into the Hall encoder signal format (U, V, W), the default simulation 5 pole motor, support the simulation pole number modification; The rotary signal can also be converted into a single-turn absolute encoder signal format (Tamagawa RS485 protocol) with a default output of 16 bits of absolute position data.

Model Summary:

Model	Input voltage	Encoder accuracy
RS10-1003I09	18-90VDC	1024 PPR
RS10-1003I16	18-180VDC	1024 PPR

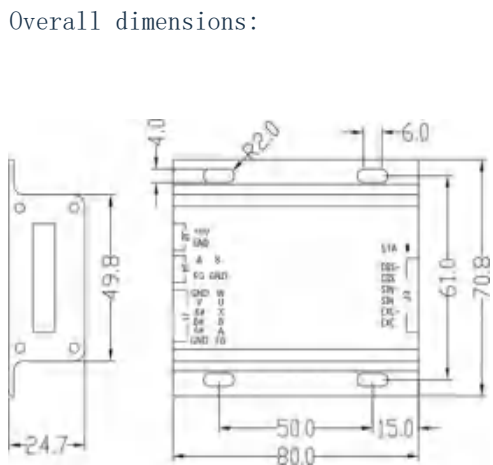

Peripheral Accessories

CR090-MRTU CAN-485



Product Overview:
 The CAN-RS485 converter realizes the conversion between the CAN bus interface and the RS485 level serial port. It CAN conveniently connect microcontroller such as single chip microcomputer, ARM and servo driver to CAN bus network to realize data sending and receiving in industrial field. The module can be widely used in industrial control, automotive electronics, security monitoring and other fields.

Model Summary:

Model	Input voltage	Remote Control Terminal
CR090-MRTU	18-90VDC	MRTU
CR180-MRTU	18-180VDC	MRTU

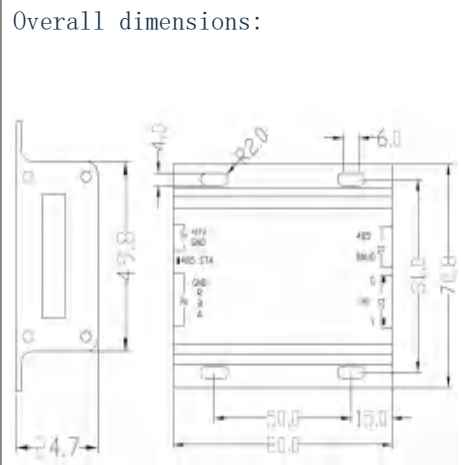

Drive Peripheral Accessories

Rectifier Modules

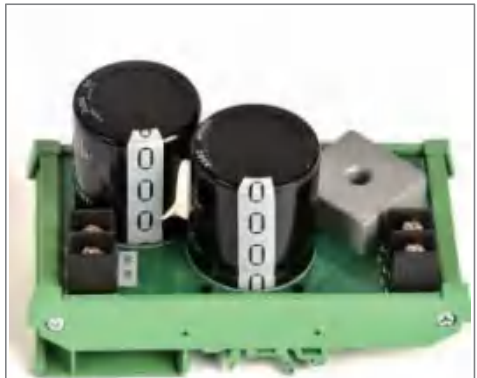

The power grid supplies AC power to users, while various radio devices require DC power. Rectification, is the process of changing alternating current into direct current. Using devices with unidirectional conductive properties, alternating current that changes direction and size can be converted to direct current.

Differential switch set photoelectric isolation card

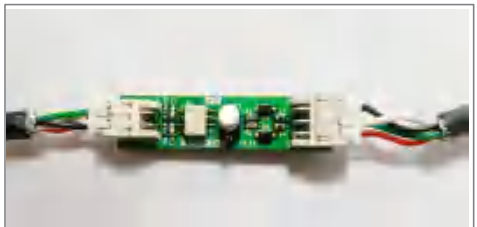

Differential to photoelectric isolator is the function of electrical isolation between signals. Can be encoder, servo drive and other output differential signal isolation conversion, directly connected to the PLC, motion control cards and other machines that can only receive open set signals, to facilitate the connection between the equipment, while the converter adopts optoelectronic isolation can improve the system's ability to resist interference, saving system resources.

Tuning line



RS-232 serial cable RJ11 to DB9P for SMS modem and various conversion devices, easy to achieve the conversion between the computer USB interface to the general serial port COM. Provides fast access to computers and laptops without serial ports.

Open set to differential photoisolation card

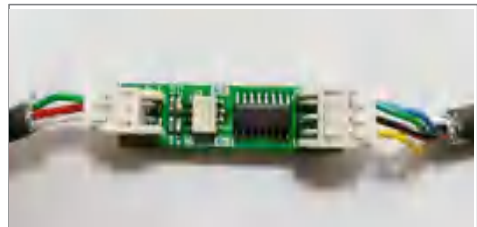

Differential optoisolator can convert differential/open-collector pulse signals into differential signals, and at the same time achieve the function of electrical isolation between the two signals. The encoder, servo drive and other output signals can be isolated and converted to differential output, extending the signal transmission distance and improving the system anti-interference, convenient for the power supply system is not the same between the equipment connection, saving system resources.

Motor introduction and model description

Servo motor comprehensive introduction

The ONK servo control system composed of DC servo permanent magnet synchronous motor and corresponding servo drive device can be widely used in transportation robots, medical treatment, machine tools, textiles, plastics, printing and dyeing, printing, building materials, packaging, woodworking, chemical and other fields.

The motor consists of a stator, a rotor, a high-precision feedback element (such as: incremental photoelectric encoder, rotary transformer, etc.). Using high-performance rare earth permanent magnet material to form an air gap magnetic field, using caseless stator core, large temperature gradient, high heat dissipation efficiency, with the following characteristics::

- ◆ Compact structure, high power density;
- ◆ Medium inertia, fast response speed;
- ◆ Ultra-high intrinsic coercivity rare earth permanent magnet material; Strong anti-demagnetization ability;
- ◆ Constant torque output in almost the entire speed range;
- ◆ Low speed torque ripple is small; High balance accuracy, high speed running smoothly;
- ◆ Low noise, low vibration; Fully sealed design; High cost performance.



Servomotor Model Description

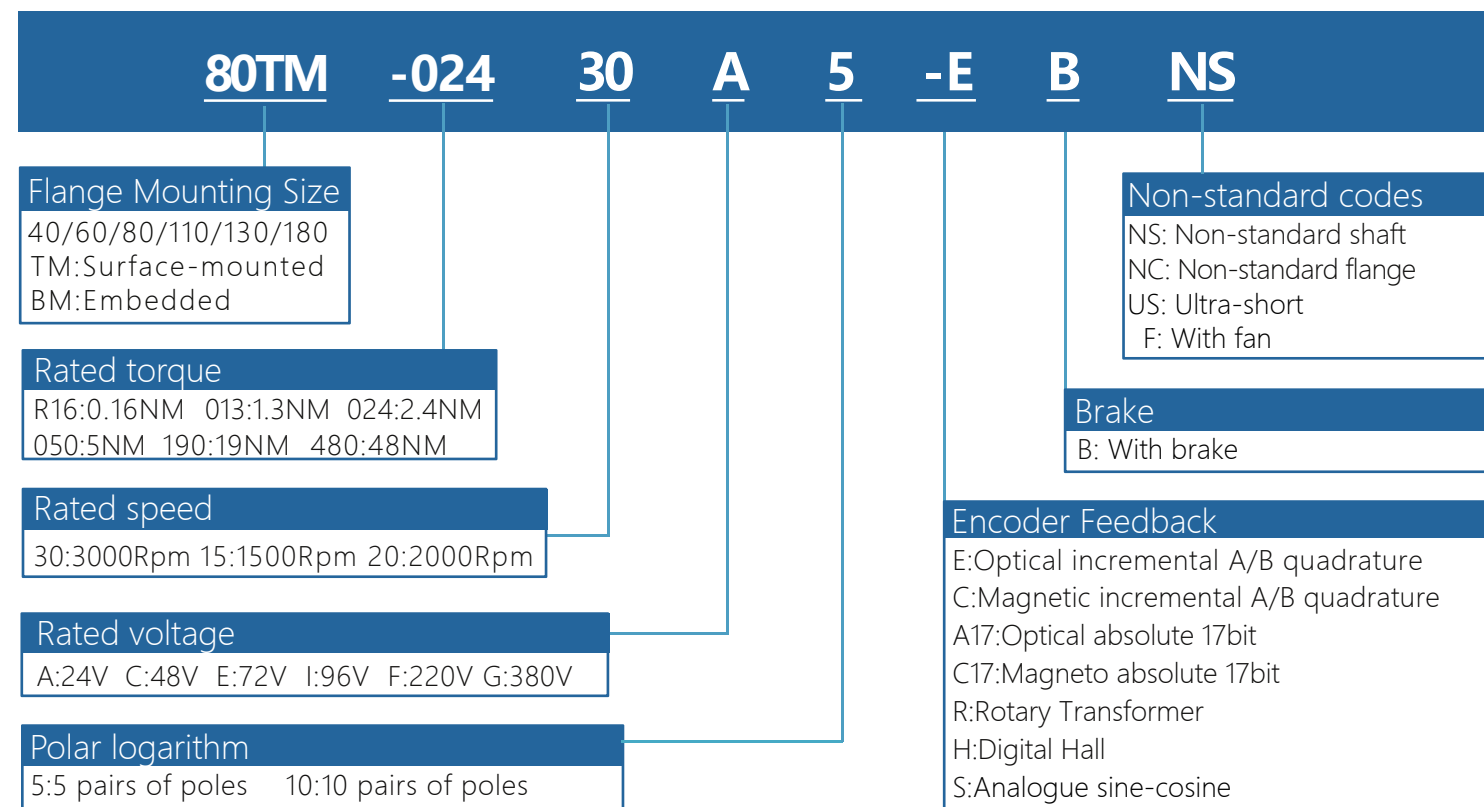

Remarks: 1.E default E25, means 2500PPR photoelectric incremental;
3.A17, denoting the photoelectric absolute value of 17bit;

2.C defaults to C25, indicating 2500PPR magneto incremental;
4.C17, denoting the magneto-electric absolute value of 17bit.

Motor Application Areas

Servomotor Application Areas

Servo motors are used in various industrial equipment, medical industry, robot industry, new energy industry, laser industry, automation industry, AGV automotive industry, control system, can convert voltage signals into torque and speed to control mechanical components, so as to achieve the purpose of operation.



Logistics automation

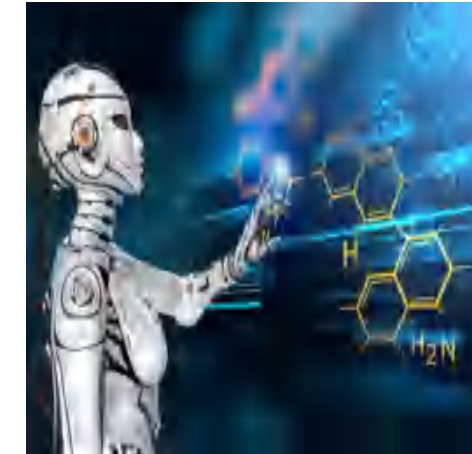

Robotics field



New energy field



Laser device



AGV vehicle



Lead screw



Medical equipment



Industrial Wire Cutting Machine



Servo control system

Motor Terminal Definition

Feedback Connector

Socket Numbers	YEGN	RD	BU	BK
Signal leads	PE	U	V	W

Power Line Socket

DC servo motor																
Socket Numbers	1	2	3	4	5	6	7	8	9	10	11	12	13	14	15	outer shell
Signal lead	Sin ₊	Sin ₋	U ₊	5V	0V	V ₊	Z ₋	Z ₊	W ₊	Cos ₊	B ₋	B ₊	A ₋	A ₊	Cos ₋	PE
Tamagawa Color	GN	GN BK	BN	RD	BK	GY	YE BK	YE	WH	BU	GN BK	GN	BU BK	BU	BU BK	
Asahi colour			BN	RD	BK	BU	YE WH	YE	ORG		GY WH	GY	GN WH	BU		

DB15 PIN terminal male

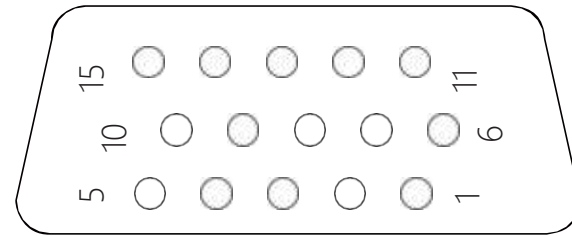

Encoder Socket

Motor characteristic curve

Torque Characteristic

Torque-speed characteristic curve

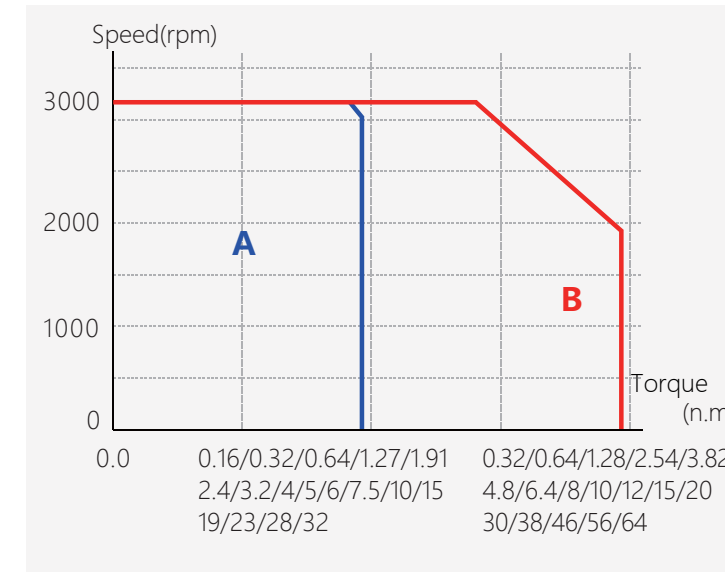

A: Continuous Duty Zone

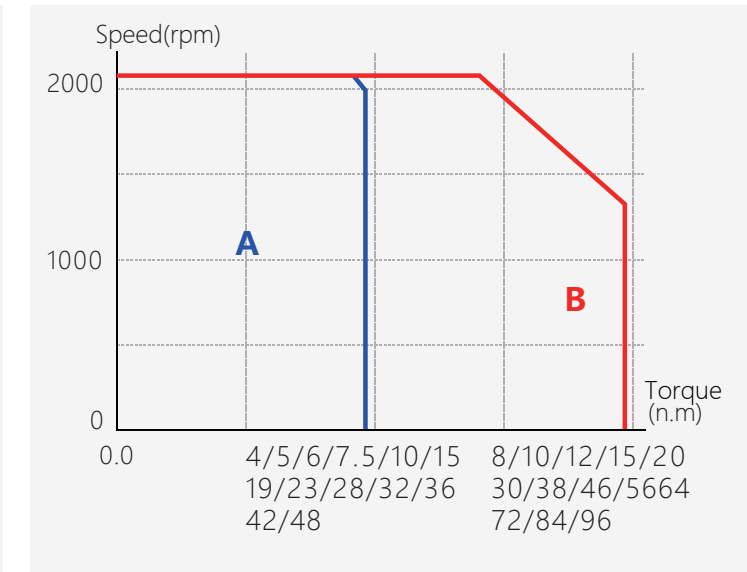

B: Intermittent Duty Zone

Phase relation between encoder zero and motor

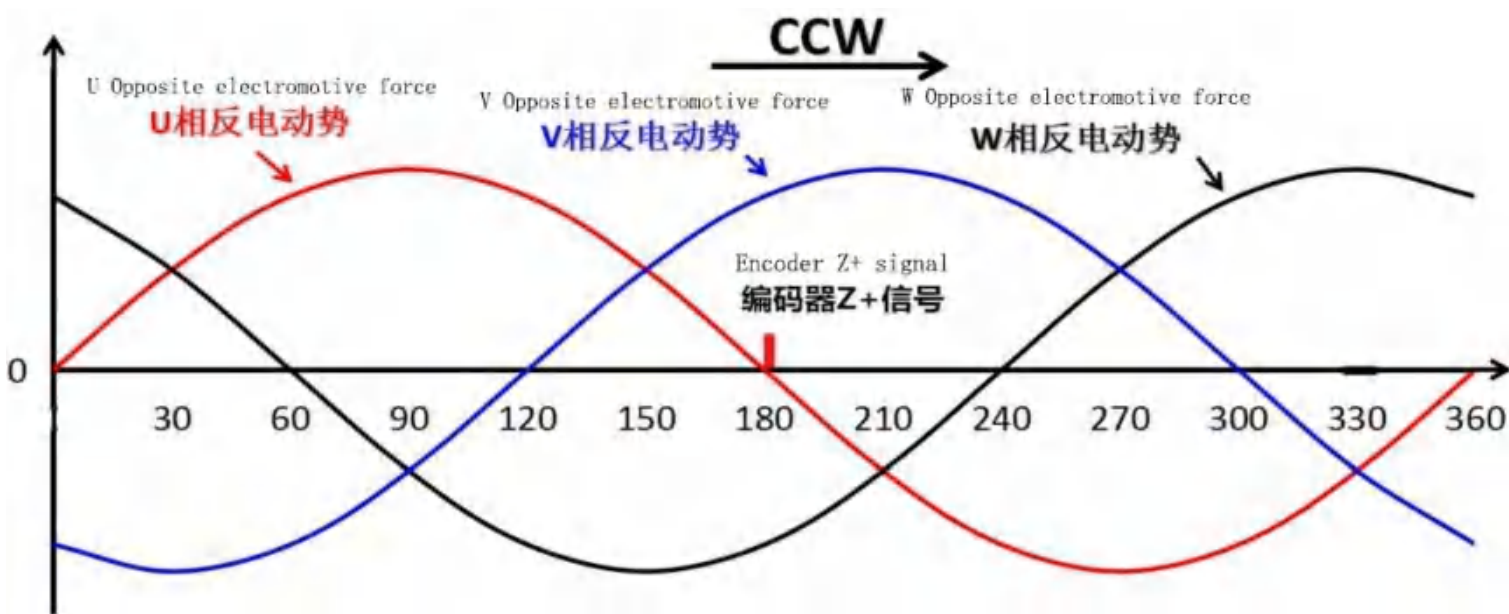

Overload characteristic curve

The operating time is set at an ambient motor temperature of 40°C and under hot start conditions.

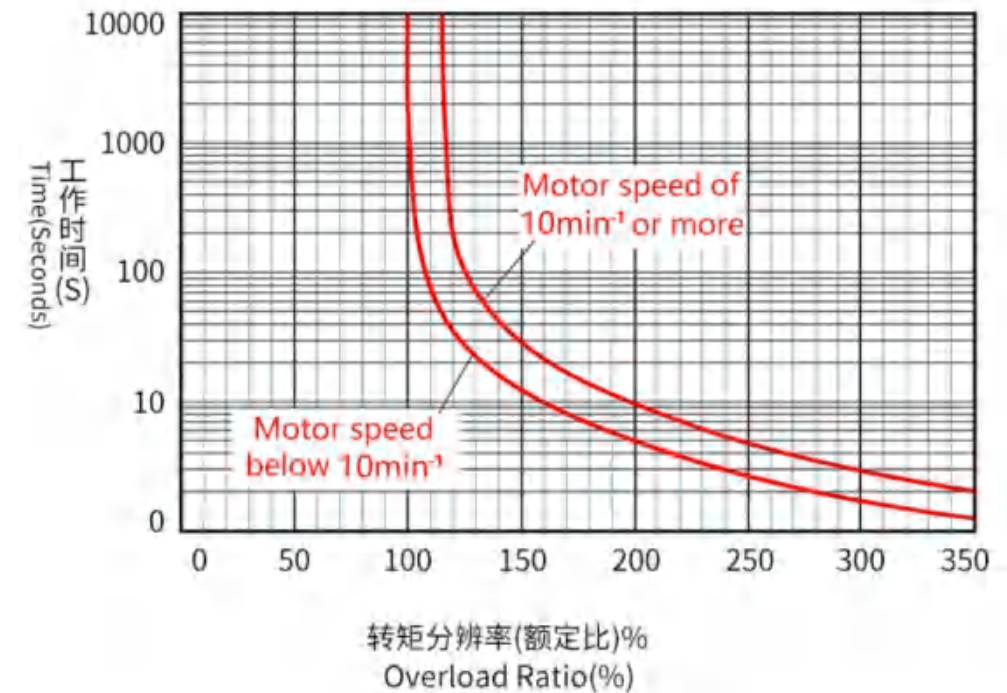

1. The above overload characteristics do not guarantee continuous use of 100% or more of the output;
2. When using the product, please make sure that the effective torque is within the continuous use range of the 'torque-speed characteristic';
3. Due to product improvement or specification change, we will update the specification in due course, please pay attention to the relevant information without prior notice.

Motor Specification Parameter Table

◆ 40 series

Motor Model	40TM-R3230A5-X	40TM-R3230C5-X
Power(W)	100	100
Rated voltage(V)	24VDC	48VDC
Rated torque(N.M)	0.32	0.32
Rated speed(rpm)	3000	3000
Rated current(Arms)	6.5±10%	3.8±10%
Torque coefficient(N.m/A)	0.05±10%	0.09±10%
Rotor inertial(kg.m ² X10 ⁻⁴)	0.06±10%	0.06±10%
Line reaction potential(V/krpm)	3.2±10%	5.7±10%
Line inductor(mH)	0.4±10%	1.1±10%
Line resistance(Ω)	0.6±10%	1.3±10%
Motor length L(mm)	82/88	82/88
With brake length LB(mm)	102/108	102/108
Weight(KG)	0.5/0.65	0.5/0.65
Feedback element X (optional)	Magneto(-C)/Photoelectric(-E)Incremental Encoder, 2500PPR, Magneto(-C17)/Photoelectric(-A17) absolute 17bit	
Insulation resistance/voltage resistance	DC500V,>20MΩ(F) / 800VAC/1s/5mA	
Usage environment	Temperature -20~40°C(-40~40°C optional); Humidity 20%~80%RH(non-condensing); Altitude below 1000(over the temperature, altitude range to reduce the rated value to use)	
Protection class	IP54 (IP65 optional)	

◆ 60 series

Motor Model	60BM-R6430A5-X	60BM-R6430C5-X	60XM-01330A5-X	60XM-01330C5-X
Power(W)	200	200	400	400
Rated voltage(V)	24VDC	48VDC	24VDC	48VDC
Rated torque(N.M)	0.64	0.64	1.27	1.27
Rated speed(rpm)	3000	3000	3000	3000
Rated current(Arms)	11±10%	5.2±10%	20±10%	11±10%
Torque coefficient(N.m/A)	0.06±10%	0.12±10%	0.06±10%	0.12±10%
Rotor inertial(kg.m ² X10 ⁻⁴)	0.3±10%	0.3±10%	0.58±10%	0.58±10%
Line reaction potential(V/krpm)	3.7±10%	7.5±10%	3.7±10%	7.5±10%
Line inductor(mH)	0.448±10%	1.648±10%	0.17±10%	1.025±10%
Line resistance(Ω)	0.169±10%	0.571±10%	0.07±10%	0.289±10%
Motor length L(mm)	78/92	78/92	97/111	97/111
With brake length LB(mm)	116/130	116/130	135/149	135/149
Weight(KG)	1/1.35	1/1.35	1.35/1.75	1.35/1.75
Feedback element X (optional)	Magneto(-C)/Photoelectric(-E)Incremental Encoder, 2500PPR, Magneto(-C17)/Photoelectric(-A17) absolute 17bit, Rotary Transformer (-R)			
Insulation resistance/voltage resistance	DC500V,>20MΩ(F) / 800VAC/1s/5mA			
Usage environment	Temperature -20~40°C(-40~40°C optional); Humidity 20%~80%RH(non-condensing); Altitude below 1000(over the temperature, altitude range to reduce the rated value to use)			
Protection class	IP54 (IP65 optional)			

Motor Specification Parameter Table

◆ 60 series

Motor Model	60BM-01930A5-X	60XM-01930C5-X	60BM-01930E5-X
Power(W)	600	600	600
Rated voltage(V)	24VDC	48VDC	72VDC
Rated torque(N.M)	1.91	1.91	1.91
Rated speed(rpm)	3000	3000	3000
Rated current(Arms)	30±10%	15.5±10%	10±10%
Torque coefficient(N.m/A)	0.06±10%	0.12±10%	0.18±10%
Rotor inertial(kg.m ² X10 ⁻⁴)	0.85±10%	0.85±10%	0.85±10%
Line reaction potential(V/krpm)	3.7±10%	7.5±10%	11±10%
Line inductor(mH)	0.156±10%	0.658±10%	0.84±10%
Line resistance(Ω)	0.052±10%	0.17±10%	0.37±10%
Motor length L(mm)	115/129	115/129	115/129
With brake length LB(mm)	153/167	153/167	153/167
Weight(KG)	1.75/2.15	1.75/2.15	1.75/2.15
Feedback element X (optional)	Magneto(-C)/Photoelectric(-E)Incremental Encoder, 2500PPR, Magneto(-C17)/Photoelectric(-A17) absolute 17bit, Rotary Transformer (-R)		
Insulation resistance/voltage resistance	DC500V,>20MΩ(F) / 800VAC/1s/5mA		
Usage environment	Temperature -20~40°C(-40~40°C optional); Humidity 20%~80%RH(non-condensing); Altitude below 1000(over the temperature, altitude range to reduce the rated value to use)		
Protection class	IP54 (IP65 optional)		

◆ 80 series

Motor Model	80BM-02430A5-X	80BM-02430C5-X	80BM-02430E5-X	80BM-03230C5-X	80BM-03230E5-X
Power(W)	750	750	750	1000	1000
Rated voltage(V)	24VDC	48VDC	72VDC	48VDC	72VDC
Rated torque(N.M)	2.4	2.4	2.4	3.2	3.2
Rated speed(rpm)	3000	3000	3000	3000	3000
Rated current(Arms)	38±10%	19.5±10%	12.5±10%	25±10%	17±10%
Torque coefficient(N.m/A)	0.06±10%	0.12±10%	0.19±10%	0.12±10%	0.18±10%
Rotor inertial(kg.m ² X10 ⁻⁴)	2.15±10%	1.7±10%	1.7±10%	2.15±10%	2.15±10%
Line reaction potential(V/krpm)	3.7±10%	7.5±10%	11.5±10%	7.5±10%	11±10%
Line inductor(mH)	0.12±10%	0.489±10%	0.3±10%	0.2±10%	±10%
Line resistance(Ω)	0.0138±10%	0.118±10%	0.85±10%	0.05±10%	±10%
Motor length L(mm)	121/134	106/120	106/120	120/134	120/134
With brake length LB(mm)	161/184	145/159	145/159	159/173	159/173
Weight(KG)	2.95/3.6	2.3/3.05	2.3/3.05	2.95/3.6	2.95/3.6
Feedback element X (optional)	Magneto(-C)/Photoelectric(-E)Incremental Encoder, 2500PPR, Magneto(-C17)/Photoelectric(-A17) absolute 17bit, Rotary Transformer (-R)				
Insulation resistance/voltage resistance	DC500V,>20MΩ(F)				
Usage environment	Temperature -20~40°C(-40~40°C optional); Humidity 20%~80%RH(non-condensing); Altitude below 1000(over the temperature, altitude range to reduce the rated value to use)				
Protection class	IP54 (IP65 optional)				

Motor Specification Parameter Table

◆ 80 series

Motor Model	80TM-01330C10-X	80TM-01330E10-X	80TM-02430C10-X	80TM-02430E10-X	80TM-03230C10-X
Power(W)	400	400	750	750	1000
Rated voltage(V)	48VDC	72VDC	48VDC	72VDC	48VDC
Rated torque(N.M)	1.3	1.27	2.4	2.4	3.2
Rated speed(rpm)	3000	3000	3000	3000	3000
Rated current(Arms)	10±10%	6.5±10%	18.5±10%	13±10%	25±10%
Torque coefficient(N.m/A)	0.13±10%	0.19±10%	0.13±10%	0.20±10%	0.13±10%
Rotor inertial(kg.m ² X10 ⁻⁴)	0.72±10%	0.72±10%	1.64±10%	1.64±10%	2.33±10%
Line reaction potential(V/krpm)	7.82±10%	11.9±10%	7.7±10%	11.5±10%	8±10%
Line inductor(mH)	0.517±10%	±10%	0.136±10%	0.313±10%	0.398±10%
Line resistance(Ω)	0.363±10%	±10%	0.114±10%	0.286±10%	0.082±10%
Motor length L(mm)	71/85	71/85	91/105	91/105	106/120
With brake length LB(mm)	110/124	110/124	130/144	130/144	145/159
Weight(KG)	1.1/1.9	1.1/1.9	1.8/2.6	1.8/2.6	2.3/3
Feedback element X (optional)	Magneto(-C)/Photoelectric(-E)Incremental Encoder, 2500PPR, Magneto(-C17)/Photoelectric(-A17) absolute 17bit, Rotary Transformer (-R)				
Insulation resistance/voltage resistance	DC500V,>20MΩ(F) / 800VAC/1s/5mA				
Usage environment	Temperature -20~40°C(-40~40°C optional); Humidity 20%~80%RH(non-condensing); Altitude below 1000(over the temperature, altitude range to reduce the rated value to use)				
Protection class	IP54 (IP65 optional)				

◆ 80 series

Motor Model	80TM-03230E10-X	80TM-04030C10-X	80TM-04030E10-X	80TM-04830C10-X	80TM-04830E10-X
Power(W)	1000	1250	1250	1500	1500
Rated voltage(V)	72VDC	48VDC	72VDC	48VDC	72VDC
Rated torque(N.M)	3.2	4	4	4.8	4.8
Rated speed(rpm)	3000	3000	3000	3000	3000
Rated current(Arms)	16.7±10%	31.5±10%	21±10%	37±10%	24±10%
Torque coefficient(N.m/A)	0.19±10%	0.13±10%	0.19±10%	0.13±10%	0.20±10%
Rotor inertial(kg.m ² X10 ⁻⁴)	2.33±10%	2.33±10%	2.33±10%	2.88±10%	2.88±10%
Line reaction potential(V/krpm)	11.6±10%	7.65±10%	11.6±10%	7.7±10%	12.1±10%
Line inductor(mH)	0.192±10%	0.079±10%	±10%	0.062±10%	0.148±10%
Line resistance(Ω)	0.14±10%	0.064±10%	±10%	0.05±10%	0.106±10%
Motor length L(mm)	106/120	106/120	106/120	120/134	120/134
With brake length LB(mm)	145/159	145/159	145/159	159/173	159/173
Weight(KG)	2.3/3	2.3/3	2.3/3	2.85/3.7	2.85/3.7
Feedback element X (optional)	Magneto(-C)/Photoelectric(-E)Incremental Encoder, 2500PPR, Magneto(-C17)/Photoelectric(-A17) absolute 17bit, Rotary Transformer (-R)				
Insulation resistance/voltage resistance	DC500V,>20MΩ(F) / 800VAC/1s/5mA				
Usage environment	Temperature -20~40°C(-40~40°C optional); Humidity 20%~80%RH(non-condensing); Altitude below 1000(over the temperature, altitude range to reduce the rated value to use)				
Protection class	IP54 (IP65 optional)				

Motor Specification Parameter Table

◆ 110 series

Motor Model	110TM-03630A5-X	110TM-04030C5-X	110TM-04030E5-X	110TM-04030I5-X
Power(W)	1100	1250	1250	1250
Rated voltage(V)	24VDC	48VDC	72VDC	96VDC
Rated torque(N.M)	3.6	4	4	4
Rated speed(rpm)	3000	3000	3000	3000
Rated current(Arms)	56±10%	29.5±10%	21±10%	15.5±10%
Torque coefficient(N.m/A)	0.06±10%	0.13±10%	0.19±10%	0.26±10%
Rotor inertial(kg.m ² X10 ⁻⁴)	7.7±10%	7.7±10%	7.7±10%	7.7±10%
Line reaction potential(V/krpm)	3.9±10%	8.16±10%	11.7±10%	15.6±10%
Line inductor(mH)	0.032±10%	0.13±10%	0.16±10%	0.56±10%
Line resistance(Ω)	0.017±10%	0.044±10%	0.024±10%	0.154±10%
Motor length L(mm)	126/139	126/139	126/139	126/139
With brake length LB(mm)	171/184	171/184	171/184	171/184
Weight(KG)	4.14/6.25	4.14/6.25	4.14/6.25	4.14/6.25
Feedback element X (optional)	Magneto(-C)/Photoelectric(-E)Incremental Encoder, 2500PPR, Magneto(-C17)/Photoelectric(-A17) absolute 17bit, Rotary Transformer (-R)			
Insulation resistance/voltage resistance	DC500V,>20MΩ(F) / 800VAC/1s/5mA			
Usage environment	Temperature -20~40°C(-40~40°C optional); Humidity 20%~80%RH(non-condensing); Altitude below 1000(over the temperature, altitude range to reduce the rated value to use)			
Protection class	IP54 (IP65 optional)			

◆ 110 series

Motor Model	110TM-05020C5-X	110TM-05020E5-X	110TM-05030A5-X	110TM-05030C5-X	110TM-05030E5-X
Power(W)	1050	1050	1550	1550	1550
Rated voltage(V)	48VDC	72VDC	24VDC	48VDC	72VDC
Rated torque(N.M)	5	5	5	5	5
Rated speed(rpm)	2000	2000	3000	3000	3000
Rated current(Arms)	26±10%	19±10%	77.5±10%	37±10%	26±10%
Torque coefficient(N.m/A)	0.19±10%	0.28±10%	0.06±10%	0.13±10%	0.19±10%
Rotor inertial(kg.m ² X10 ⁻⁴)	7.7±10%	7.7±10%	7.7±10%	7.7±10%	7.7±10%
Line reaction potential(V/krpm)	11.7±10%	16.3±10%	3.9±10%	6.8±10%	11.7±10%
Line inductor(mH)	0.16±10%	±10%	±10%	0.104±10%	0.292±10%
Line resistance(Ω)	0.024±10%	±10%	±10%	0.032±10%	0.08±10%
Motor length L(mm)	126/139	126/139	126/139	126/139	126/139
With brake length LB(mm)	171/184	171/184	171/184	171/184	171/184
Weight(KG)	4.14/6.25	4.14/6.25	4.14/6.25	4.14/6.25	4.14/6.25
Feedback element X (optional)	Magneto(-C)/Photoelectric(-E)Incremental Encoder, 2500PPR, Magneto(-C17)/Photoelectric(-A17) absolute 17bit, Rotary Transformer (-R)				
Insulation resistance/voltage resistance	DC500V,>20MΩ(F) / 800VAC/1s/5mA				
Usage environment	Temperature -20~40°C(-40~40°C optional); Humidity 20%~80%RH(non-condensing); Altitude below 1000(over the temperature, altitude range to reduce the rated value to use)				
Protection class	IP54 (IP65 optional)				

Motor Specification Parameter Table

◆ 110 series

Motor Model	110TM-06020C5-X	110TM-06020E5-X	110TM-06030C5-X	110TM-06030E5-X	110TM-07520C5-X
Power(W)	1250	1250	1880	1880	1570
Rated voltage(V)	48VDC	72VDC	48VDC	72VDC	48VDC
Rated torque(N.M)	6	6	6	6	7.5
Rated speed(rpm)	2000	2000	3000	3000	2000
Rated current(Arms)	32±10%	22±10%	46±10%	31±10%	39±10%
Torque coefficient(N.m/A)	0.19±10%	0.27±10%	0.128±10%	0.19±10%	0.19±10%
Rotor inertial(kg.m ² X10 ⁻⁴)	10.9±10%	10.9±10%	10.9±10%	10.9±10%	10.9±10%
Line reaction potential(V/krpm)	11.6±10%	16.5±10%	7.2±10%	11.6±10%	11.6±10%
Line inductor(mH)	0.162±10%	±10%	0.064±10%	0.187±10%	±10%
Line resistance(Ω)	0.072±10%	±10%	0.023±10%	0.053±10%	±10%
Motor length L(mm)	156/169	156/169	156/169	156/169	156/169
With brake length LB(mm)	193/206	193/206	193/206	193/206	193/206
Weight(KG)	6.36/8.47	6.36/8.47	6.36/8.47	6.36/8.47	6.36/8.47
Feedback element X (optional)	Magneto(-C)/Photoelectric(-E)Incremental Encoder, 2500PPR, Magneto(-C17)/Photoelectric(-A17) absolute 17bit, Rotary Transformer (-R)				
Insulation resistance/voltage resistance	DC500V,>20MΩ(F) / 800VAC/1s/5mA				
Usage environment	Temperature -20~40°C(-40~40°C optional); Humidity 20%~80%RH(non-condensing); Altitude below 1000(over the temperature, altitude range to reduce the rated value to use)				
Protection class	IP54 (IP65 optional)				

◆ 110 series

Motor Model	110TM-07520E5-X	110TM-07530C5-X	110TM-07530E5-X	110TM-07530I5-X	110TM-07530M5-X
Power(W)	1570	2350	2350	2350	2350
Rated voltage(V)	72VDC	48VDC	72VDC	96VDC	144VDC
Rated torque(N.M)	7.5	7.5	7.5	7.5	7.5
Rated speed(rpm)	2000	3000	3000	3000	3000
Rated current(Arms)	27±10%	59±10%	39±10%	28.5±10%	19±10%
Torque coefficient(N.m/A)	0.28±10%	0.13±10%	0.19±10%	0.26±10%	0.4±10%
Rotor inertial(kg.m ² X10 ⁻⁴)	10.9±10%	10.9±10%	10.9±10%	10.9±10%	10.9±10%
Line reaction potential(V/krpm)	17.3±10%	7.7±10%	11.6±10%	16±10%	24±10%
Line inductor(mH)	0.415±10%	0.081±10%	±10%	±10%	±10%
Line resistance(Ω)	0.102±10%	0.032±10%	±10%	±10%	±10%
Motor length L(mm)	156/169	156/169	156/169	156/169	156/169
With brake length LB(mm)	193/206	193/206	193/206	193/206	193/206
Weight(KG)	6.36/8.47	6.36/8.47	6.36/8.47	6.36/8.47	6.36/8.47
Feedback element X (optional)	Magneto(-C)/Photoelectric(-E)Incremental Encoder, 2500PPR, Magneto(-C17)/Photoelectric(-A17) absolute 17bit, Rotary Transformer (-R)				
Insulation resistance/voltage resistance	DC500V,>20MΩ(F) / 800VAC/1s/5mA				
Usage environment	Temperature -20~40°C(-40~40°C optional); Humidity 20%~80%RH(non-condensing); Altitude below 1000(over the temperature, altitude range to reduce the rated value to use)				
Protection class	IP54 (IP65 optional)				

Motor Specification Parameter Table

◆ 130 series

Motor Model	130TM-05020C5-X	130TM-05030A5-X	130TM-05030C5-X	130TM-05030E5-X
Power(W)	1050	1550	1550	1550
Rated voltage(V)	48VDC	24VDC	48VDC	72VDC
Rated torque(N.M)	5	5	5	5
Rated speed(rpm)	2000	3000	3000	3000
Rated current(Arms)	30±10%	75.5±10%	37±10%	26±10%
Torque coefficient(N.m/A)	0.18±10%	0.06±10%	0.12±10%	0.20±10%
Rotor inertial(kg.m ² X10 ⁻⁴)	12±10%	12±10%	12±10%	12±10%
Line reaction potential(V/krpm)	11.2±10%	4±10%	7.6±10%	11.8±10%
Line inductor(mH)	0.212±10%	0.027±10%	0.106±10%	±10%
Line resistance(Ω)	0.052±10%	0.014±10%	0.033±10%	±10%
Motor length L(mm)	119/132	119/132	119/132	119/132
With brake length LB(mm)	166/179	166/179	166/179	166/179
Weight(KG)	6/7.8	6/7.8	6/7.8	6/7.8
Feedback element X (optional)	Magneto(-C)/Photoelectric(-E)Incremental Encoder, 2500PPR, Magneto(-C17)/Photoelectric(-A17) absolute 17bit, Rotary Transformer (-R)			
Insulation resistance/voltage resistance	DC500V,>20MΩ(F) / 800VAC/1s/5mA			
Usage environment	Temperature -20~40°C(-40~40°C optional); Humidity 20%~80%RH(non-condensing); Altitude below 1000(over the temperature, altitude range to reduce the rated value to use)			
Protection class	IP54 (IP65 optional)			

◆ 130 series

Motor Model	130TM-07530A5-X	130TM-07520C5-X	130TM-07520E5-X	130TM-07530C5-X
Power(W)	2350	1570	1570	2350
Rated voltage(V)	24VDC	48VDC	72VDC	48VDC
Rated torque(N.M)	7.5	7.5	7.5	7.5
Rated speed(rpm)	3000	2000	2000	3000
Rated current(Arms)	113±10%	39±10%	27.5±10%	59±10%
Torque coefficient(N.m/A)	0.066±10%	0.19±10%	0.27±10%	0.12±10%
Rotor inertial(kg.m ² X10 ⁻⁴)	12.9±10%	12.9±10%	12.9±10%	12.9±10%
Line reaction potential(V/krpm)	4±10%	11.5±10%	16.5±10%	7.7±10%
Line inductor(mH)	±10%	±10%	±10%	0.065±10%
Line resistance(Ω)	±10%	±10%	±10%	0.021±10%
Motor length L(mm)	149/162	134/147	134/147	134/147
With brake length LB(mm)	196/209	181/194	181/194	181/194
Weight(KG)	8/9.8	8/9.8	8/9.8	8/9.8
Feedback element X (optional)	Magneto(-C)/Photoelectric(-E)Incremental Encoder, 2500PPR, Magneto(-C17)/Photoelectric(-A17) absolute 17bit, Rotary Transformer (-R)			
Insulation resistance/voltage resistance	DC500V,>20MΩ(F) / 800VAC/1s/5mA			
Usage environment	Temperature -20~40°C(-40~40°C optional); Humidity 20%~80%RH(non-condensing); Altitude below 1000(over the temperature, altitude range to reduce the rated value to use)			
Protection class	IP54 (IP65 optional)			

Motor Specification Parameter Table

◆130 series

Motor Model	130TM-07530E5-X	130TM-10020C5-X	130TM-10020E5-X	130TM-10030C5-X	130TM-10030E5-X
Power(W)	2350	2100	2100	3150	3150
Rated voltage(V)	72VDC	48VDC	72VDC	48VDC	72VDC
Rated torque(N.M)	7.5	10	10	10	10
Rated speed(rpm)	3000	2000	2000	3000	3000
Rated current(Arms)	39±10%	52.5±10%	36.5±10%	78±10%	52.5±10%
Torque coefficient(N.m/A)	0.19±10%	0.19±10%	0.27±10%	0.12±10%	0.19±10%
Rotor inertial(kg.m ² X10 ⁻⁴)	12.9±10%	12.9±10%	12.9±10%	12.9±10%	12.9±10%
Line reaction potential(V/krpm)	11.6±10%	11.5±10%	16.6±10%	7.7±10%	11.5±10%
Line inductor(mH)	0.151±10%	0.188±10%	0.8±10%	±10%	±10%
Line resistance(Ω)	0.057±10%	0.049±10%	0.07±10%	±10%	±10%
Motor length L(mm)	134/147	149/162	149/162	149/162	149/162
With brake length LB(mm)	181/194	196/209	196/209	196/209	196/209
Weight(KG)	8/9.8	8/9.8	8/9.8	8/9.8	8/9.8
Feedback element X (optional)	Magneto(-C)/Photoelectric(-E)Incremental Encoder, 2500PPR, Magneto(-C17)/Photoelectric(-A17) absolute 17bit, Rotary Transformer (-R)				
Insulation resistance/voltage resistance	DC500V,>20MΩ(F) / 800VAC/1s/5mA				
Usage environment	Temperature -20~40°C(-40~40°C optional); Humidity 20%~80%RH(non-condensing); Altitude below 1000(over the temperature, altitude range to reduce the rated value to use)				
Protection class	IP54 (IP65 optional)				

◆130 series

Motor Model	130TM-10030I5-X	130TM-10030M5-X	130TM-15020C5-X	130TM-15020E5-X	130TM-15025C5-X
Power(W)	3150	3150	3150	3150	3800
Rated voltage(V)	96VDC	144VDC	48VDC	72VDC	48VDC
Rated torque(N.M)	10	10	15	15	15
Rated speed(rpm)	3000	3000	2000	2000	2500
Rated current(Arms)	38.6±10%	25.3±10%	81±10%	56.5±10%	94±10%
Torque coefficient(N.m/A)	0.26±10%	0.4±10%	0.18±10%	0.26±10%	0.16±10%
Rotor inertial(kg.m ² X10 ⁻⁴)	12.9±10%	12.9±10%	17±10%	17±10%	17±10%
Line reaction potential(V/krpm)	15.6±10%	24±10%	11.2±10%	16±10%	9.6±10%
Line inductor(mH)	±10%	±10%	0.26±10%	±10%	±10%
Line resistance(Ω)	±10%	±10%	0.02±10%	±10%	±10%
Motor length L(mm)	149/162	149/162	166/179	166/179	166/179
With brake length LB(mm)	196/209	196/209	221/234	221/234	221/234
Weight(KG)	8/9.8	8/9.8	11/12.8	11/12.8	11/12.8
Feedback element X (optional)	Magneto(-C)/Photoelectric(-E)Incremental Encoder, 2500PPR, Magneto(-C17)/Photoelectric(-A17) absolute 17bit, Rotary Transformer (-R)				
Insulation resistance/voltage resistance	DC500V,>20MΩ(F) / 800VAC/1s/5mA				
Usage environment	Temperature -20~40°C(-40~40°C optional); Humidity 20%~80%RH(non-condensing); Altitude below 1000(over the temperature, altitude range to reduce the rated value to use)				
Protection class	IP54 (IP65 optional)				

Motor Specification Parameter Table

◆130 series

Motor Model	130TM-15030C5-XF	130TM-15030E5-XF	130TM-15030I5-XF	130TM-15030M5-XF	130TM-16030C5-XF
Power(W)	4700	4700	4700	4700	5000
Rated voltage(V)	48VDC	72VDC	96VDC	144VDC	48VDC
Rated torque(N.M)	15	15	15	15	16
Rated speed(rpm)	3000	3000	3000	3000	3000
Rated current(Arms)	112±10%	81±10%	57±10%	38±10%	120±10%
Torque coefficient(N.m/A)	0.13±10%	0.18±10%	0.264±10%	0.4±10%	0.12±10%
Rotor inertial(kg.m ² X10 ⁻⁴)	17±10%	17±10%	17±10%	17±10%	25.2±10%
Line reaction potential(V/krpm)	8±10%	11.2±10%	16±10%	24±10%	7.7±10%
Line inductor(mH)	0.26±10%	0.26±10%	±10%	±10%	0.66±10%
Line resistance(Ω)	0.019±10%	0.019±10%	±10%	±10%	0.04±10%
Motor length L(mm)	220/233	220/233	220/233	220/233	235/248
With brake length LB(mm)	260/273	260/273	260/273	260/273	260/273
Weight(KG)	11/12.8	11/12.8	11/12.8	11/12.8	14/15.8
Feedback element X (optional)	Magneto(-C)/Photoelectric(-E)Incremental Encoder, 2500PPR, Magneto(-C17)/Photoelectric(-A17) absolute 17bit, Rotary Transformer (-R); With fan (-F)				
Insulation resistance/voltage resistance	DC500V,>20MΩ(F) / 800VAC/1s/5mA				
Usage environment	Temperature -20~40°C(-40~40°C optional); Humidity 20%~80%RH(non-condensing); Altitude below 1000(over the temperature, altitude range to reduce the rated value to use)				
Protection class	IP54 (IP65 optional)				

◆130 series

Motor Model	130TM-16030E5-XF	130TM-19015C5-X	130TM-19015E5-X	130TM-19020C5-X	130TM-19020E5-X
Power(W)	5000	3000	3000	4000	4000
Rated voltage(V)	72VDC	48VDC	72VDC	48VDC	72VDC
Rated torque(N.M)	16	19	19	19	19
Rated speed(rpm)	3000	1500	1500	2000	2000
Rated current(Arms)	84±10%	75±10%	54.5±10%	99.5±10%	66.5±10%
Torque coefficient(N.m/A)	0.19±10%	0.25±10%	0.34±10%	0.19±10%	0.28±10%
Rotor inertial(kg.m ² X10 ⁻⁴)	25.2±10%	25.2±10%	25.2±10%	25.2±10%	25.2±10%
Line reaction potential(V/krpm)	11.5±10%	15.36±10%	21.1±10%	11.5±10%	17.2±10%
Line inductor(mH)	0.66±10%	0.66±10%	0.66±10%	0.66±10%	0.66±10%
Line resistance(Ω)	0.04±10%	0.04±10%	0.04±10%	0.04±10%	0.04±10%
Motor length L(mm)	224/237	181/194	181/194	196/209	181/194
With brake length LB(mm)	264/277	221/234	221/234	221/234	221/234
Weight(KG)	14/15.8	14/15.8	14/15.8	14/15.8	14/15.8
Feedback element X (optional)	Magneto(-C)/Photoelectric(-E)Incremental Encoder, 2500PPR, Magneto(-C17)/Photoelectric(-A17) absolute 17bit, Rotary Transformer (-R); With fan (-F)				
Insulation resistance/voltage resistance	DC500V,>20MΩ(F) / 800VAC/1s/5mA				
Usage environment	Temperature -20~40°C(-40~40°C optional); Humidity 20%~80%RH(non-condensing); Altitude below 1000(over the temperature, altitude range to reduce the rated value to use)				
Protection class	IP54 (IP65 optional)				

Motor Specification Parameter Table

◆ 180 series

Motor Model	180TM-10030A5-X	180TM-15015C5-X	180TM-15015E5-X	180TM-15020C5-X	180TM-15020E5-X
Power(W)	3000	2350	2350	3000	3000
Rated voltage(V)	24VDC	48VDC	72VDC	48VDC	72VDC
Rated torque(N.M)	10	15	15	15	15
Rated speed(rpm)	3000	1500	1500	2000	2000
Rated current(Arms)	133.5±10%	59±10%	42±10%	82±10%	52±10%
Torque coefficient(N.m/A)	0.07±10%	0.25±10%	0.35±10%	0.18±10%	0.29±10%
Rotor inertial(kg.m ² X10 ⁻⁴)	60±10%	60±10%	60±10%	90±10%	90±10%
Line reaction potential(V/krpm)	4.5±10%	15.3±10%	21.4±10%	11±10%	17.4±10%
Line inductor(mH)	0.07±10%	±10%	±10%	±10%	±10%
Line resistance(Ω)	0.005±10%	±10%	±10%	±10%	±10%
Motor length L(mm)	183	183	183	213(183)	213(183)
With brake length LB(mm)	276	276	276	276	276
Weight(KG)	14.5/32	14.5/32	14.5/32	18.9/32	18.9/32
Feedback element X (optional)	Magneto(-C)/Photoelectric(-E)Incremental Encoder, 2500PPR, Magneto(-C17)/Photoelectric(-A17) absolute 17bit, Rotary Transformer (-R)				
Insulation resistance/voltage resistance	DC500V,>20MΩ(F) / 800VAC/1s/5mA				
Usage environment	Temperature -20~40°C(-40~40°C optional); Humidity 20%~80%RH(non-condensing); Altitude below 1000(over the temperature, altitude range to reduce the rated value to use)				
Protection class	IP54 (IP65 optional)				

◆ 180 series

Motor Model	180TM-19015C5-X	180TM-19015E5-X	180TM-19020C5-X	180TM-19020E5-X	180TM-19020I5-X
Power(W)	3000	3000	4000	4000	4000
Rated voltage(V)	48VDC	72VDC	48VDC	72VDC	96VDC
Rated torque(N.M)	19	19	19	19	19
Rated speed(rpm)	1500	1500	2000	2000	2000
Rated current(Arms)	79±10%	53.5±10%	99±10%	68±10%	50±10%
Torque coefficient(N.m/A)	0.26±10%	0.36±10%	0.19±10%	0.29±10%	0.37±10%
Rotor inertial(kg.m ² X10 ⁻⁴)	60±10%	60±10%	90±10%	90±10%	90±10%
Line reaction potential(V/krpm)	14.5±10%	21.7±10%	11.6±10%	17.4±10%	22.6±10%
Line inductor(mH)	±10%	±10%	0.101±10%	0.19±10%	±10%
Line resistance(Ω)	±10%	±10%	0.015±10%	0.016±10%	±10%
Motor length L(mm)	183	183	213(183)	213(183)	213(183)
With brake length LB(mm)	276	276	276	276	276
Weight(KG)	14.5/32	14.5/32	18.9/32	18.9/32	18.9/32
Feedback element X (optional)	Magneto(-C)/Photoelectric(-E)Incremental Encoder, 2500PPR, Magneto(-C17)/Photoelectric(-A17) absolute 17bit, Rotary Transformer (-R)				
Insulation resistance/voltage resistance	DC500V,>20MΩ(F) / 800VAC/1s/5mA				
Usage environment	Temperature -20~40°C(-40~40°C optional); Humidity 20%~80%RH(non-condensing); Altitude below 1000(over the temperature, altitude range to reduce the rated value to use)				
Protection class	IP54 (IP65 optional)				

Motor Specification Parameter Table

◆ 180 series

Motor Model	180TM-19020M5-X	180TM-23015C5-X	180TM-23015E5-X	180TM-23020C5-X	180TM-23020E5-X
Power(W)	4000	3600	3600	4800	4800
Rated voltage(V)	144VDC	48VDC	72VDC	48VDC	72VDC
Rated torque(N.M)	19	23	23	23	23
Rated speed(rpm)	2000	1500	1500	2000	2000
Rated current(Arms)	33±10%	87±10%	64±10%	120±10%	80±10%
Torque coefficient(N.m/A)	0.57±10%	0.25±10%	0.36±10%	0.19±10%	0.28±10%
Rotor inertial(kg.m ² X10 ⁻⁴)	122±10%	60±10%	60±10%	122±10%	122±10%
Line reaction potential(V/krpm)	34.8±10%	15.9±10%	21.7±10%	11.5±10%	17.3±10%
Line inductor(mH)	±10%	±10%	±10%	±10%	±10%
Line resistance(Ω)	±10%	±10%	±10%	±10%	±10%
Motor length L(mm)	238	183	183	238	238
With brake length LB(mm)	331	276	276	331	331(276)
Weight(KG)	22.7/34	14.5/32	14.5/32	22.7/34	22.7/34
Feedback element X (optional)	Magneto(-C)/Photoelectric(-E)Incremental Encoder, 2500PPR, Magneto(-C17)/Photoelectric(-A17) absolute 17bit, Rotary Transformer (-R); With fan (-F)				
Insulation resistance/voltage resistance	DC500V,>20MΩ(F) / 800VAC/1s/5mA				
Usage environment	Temperature -20~40°C(-40~40°C optional); Humidity 20%~80%RH(non-condensing); Altitude below 1000(over the temperature, altitude range to reduce the rated value to use)				
Protection class	IP54 (IP65 optional)				

◆ 180 series

Motor Model	180TM-24020C5-X	180TM-24030E5-XF	180TM-24030I5-XF	180TM-28015C5-X	180TM-28015E5-X
Power(W)	5000	7500	7500	4400	4400
Rated voltage(V)	48VDC	72VDC	96VDC	48VDC	72VDC
Rated torque(N.M)	24	24	24	28	28
Rated speed(rpm)	2000	3000	3000	1500	1500
Rated current(Arms)	126±10%	123±10%	91±10%	112±10%	76±10%
Torque coefficient(N.m/A)	0.19±10%	0.20±10%	0.26±10%	0.25±10%	0.37±10%
Rotor inertial(kg.m ² X10 ⁻⁴)	122±10%	150±10%	150±10%	90±10%	90±10%
Line reaction potential(V/krpm)	11.5±10%	11.8±10%	16±10%	15±10%	22.2±10%
Line inductor(mH)	±10%	±10%	±10%	±10%	±10%
Line resistance(Ω)	±10%	±10%	±10%	±10%	±10%
Motor length L(mm)	238	331	331	213	213
With brake length LB(mm)	331	386	386	276	276
Weight(KG)	22.7/34	32/34	32/34	18.9/32	18.9/32
Feedback element X (optional)	Magneto(-C)/Photoelectric(-E)Incremental Encoder, 2500PPR, Magneto(-C17)/Photoelectric(-A17) absolute 17bit, Rotary Transformer (-R); With fan (-F)				
Insulation resistance/voltage resistance	DC500V,>20MΩ(F) / 800VAC/1s/5mA				
Usage environment	Temperature -20~40°C(-40~40°C optional); Humidity 20%~80%RH(non-condensing); Altitude below 1000(over the temperature, altitude range to reduce the rated value to use)				
Protection class	IP54 (IP65 optional)				

Motor Specification Parameter Table

◆ 180 series

Motor Model	180TM-28020C5-X	180TM-28020E5-X	180TM-28030E5-XF	180TM-28030I5-XF	180TM-28030M5-XF
Power(W)	5800	5800	8800	8800	8800
Rated voltage(V)	48VDC	72VDC	72VDC	96VDC	144VDC
Rated torque(N.M)	28	28	28	28	28
Rated speed(rpm)	2000	2000	3000	3000	3000
Rated current(Arms)	137±10%	100±10%	144±10%	109±10%	70±10%
Torque coefficient(N.m/A)	0.20±10%	0.28±10%	0.20±10%	0.25±10%	0.4±10%
Rotor inertial(kg.m ² X10 ⁻⁴)	122±10%	122±10%	150±10%	150±10%	150±10%
Line reaction potential(V/krpm)	12.3±10%	17.3±10%	11.8±10%	15.5±10%	24±10%
Line inductor(mH)	0.049±10%	0.122±10%	±10%	0.13±10%	±10%
Line resistance(Ω)	0.005±10%	0.0125±10%	±10%	0.005±10%	±10%
Motor length L(mm)	238	238	331	331	331
With brake length LB(mm)	331	331(276)	386	386	386
Weight(KG)	22.7/34	22.7/34	32/34	32/34	32/34
Feedback element X (optional)	Magneto(-C)/Photoelectric(-E)Incremental Encoder, 2500PPR, Magneto(-C17)/Photoelectric(-A17) absolute 17bit, Rotary Transformer (-R); With fan (-F)				
Insulation resistance/voltage resistance	DC500V,>20MΩ(F) / 800VAC/1s/5mA				
Usage environment	Temperature -20~40°C(-40~40°C optional); Humidity 20%~80%RH(non-condensing); Altitude below 1000(over the temperature, altitude range to reduce the rated value to use)				
Protection class	IP54 (IP65 optional)				

◆ 180 series

Motor Model	180TM-32015E5-X	180TM-32020C5-X	180TM-32020E5-X	180TM-32030E5-XF	180TM-32030I5-XF
Power(W)	5000	6700	6700	10000	10000
Rated voltage(V)	72VDC	48VDC	72VDC	72VDC	96VDC
Rated torque(N.M)	32	32	32	32	32
Rated speed(rpm)	1500	2000	2000	3000	3000
Rated current(Arms)	89±10%	165±10%	110±10%	162±10%	128±10%
Torque coefficient(N.m/A)	0.36±10%	0.20±10%	0.29±10%	0.20±10%	0.25±10%
Rotor inertial(kg.m ² X10 ⁻⁴)	122±10%	150±10%	150±10%	150±10%	153±10%
Line reaction potential(V/krpm)	21.8±10%	11.7±10%	17.5±10%	12±10%	15±10%
Line inductor(mH)	±10%	±10%	±10%	±10%	±10%
Line resistance(Ω)	±10%	±10%	±10%	±10%	±10%
Motor length L(mm)	238	276	276	331	331
With brake length LB(mm)	331	331	331	386	386
Weight(KG)	22.7/34	32/34	32/34	32/34	32/34
Feedback element X (optional)	Magneto(-C)/Photoelectric(-E)Incremental Encoder, 2500PPR, Magneto(-C17)/Photoelectric(-A17) absolute 17bit, Rotary Transformer (-R); With fan (-F)				
Insulation resistance/voltage resistance	DC500V,>20MΩ(F) / 800VAC/1s/5mA				
Usage environment	Temperature -20~40°C(-40~40°C optional); Humidity 20%~80%RH(non-condensing); Altitude below 1000(over the temperature, altitude range to reduce the rated value to use)				
Protection class	IP54 (IP65 optional)				

Motor Specification Parameter Table

◆ 180 series

Motor Model	180TM-35020E5-X	180TM-36015C5-X	180TM-36015E5-X	180TM-36015I5-X	180TM-42015C5-X
Power(W)	7000	5500	5500	5500	6600
Rated voltage(V)	72VDC	48VDC	72VDC	96VDC	48VDC
Rated torque(N.M)	35	36	36	36	42
Rated speed(rpm)	2000	1500	1500	1500	1500
Rated current(Arms)	121±10%	136±10%	97±10%	76±10%	160±10%
Torque coefficient(N.m/A)	0.29±10%	0.26±10%	0.36±10%	0.47±10%	0.26±10%
Rotor inertial(kg.m ² X10 ⁻⁴)	150±10%	122±10%	122±10%	122±10%	150±10%
Line reaction potential(V/krpm)	17.5±10%	15.5±10%	21.8±10%	28.5±10%	15.8±10%
Line inductor(mH)	±10%	±10%	±10%	±10%	0.06±10%
Line resistance(Ω)	±10%	±10%	±10%	±10%	0.084±10%
Motor length L(mm)	276	238	238	238	276
With brake length LB(mm)	331	331	331	331	331
Weight(KG)	32/34	22.7/34	22.7/34	22.7/34	32/34
Feedback element X (optional)	Magneto(-C)/Photoelectric(-E)Incremental Encoder, 2500PPR, Magneto(-C17)/Photoelectric(-A17) absolute 17bit, Rotary Transformer (-R); With fan (-F)				
Insulation resistance/voltage resistance	DC500V,>20MΩ(F) / 800VAC/1s/5mA				
Usage environment	Temperature -20~40°C(-40~40°C optional); Humidity 20%~80%RH(non-condensing); Altitude below 1000(over the temperature, altitude range to reduce the rated value to use)				
Protection class	IP54 (IP65 optional)				

◆ 180 series

Motor Model	180TM-42015E5-X	180TM-42020E5-X	180TM-42020I5-X	180TM-48015E5-X	180TM-48020E5-X
Power(W)	6600	8800	8800	7500	10000
Rated voltage(V)	72VDC	72VDC	96VDC	72VDC	72VDC
Rated torque(N.M)	42	42	42	48	48
Rated speed(rpm)	1500	2000	2000	1500	2000
Rated current(Arms)	121.5±10%	132±10%	113±10%	136±10%	178±10%
Torque coefficient(N.m/A)	0.34±10%	0.29±10%	0.37±10%	0.36±10%	0.27±10%
Rotor inertial(kg.m ² X10 ⁻⁴)	150±10%	150±10%	153±10%	150±10%	153±10%
Line reaction potential(V/krpm)	21±10%	17.5±10%	21±10%	21.7±10%	16.2±10%
Line inductor(mH)	±10%	±10%	±10%	±10%	±10%
Line resistance(Ω)	±10%	±10%	±10%	±10%	±10%
Motor length L(mm)	276	276	276	276	276
With brake length LB(mm)	331	331	331	331	331
Weight(KG)	32/34	32/34	34/34	32/34	34/34
Feedback element X (optional)	Magneto(-C)/Photoelectric(-E)Incremental Encoder, 2500PPR, Magneto(-C17)/Photoelectric(-A17) absolute 17bit, Rotary Transformer (-R); With fan (-F)				
Insulation resistance/voltage resistance	DC500V,>20MΩ(F) / 800VAC/1s/5mA				
Usage environment	Temperature -20~40°C(-40~40°C optional); Humidity 20%~80%RH(non-condensing); Altitude below 1000(over the temperature, altitude range to reduce the rated value to use)				
Protection class	IP54 (IP65 optional)				

Motor external dimensions

External Dimension

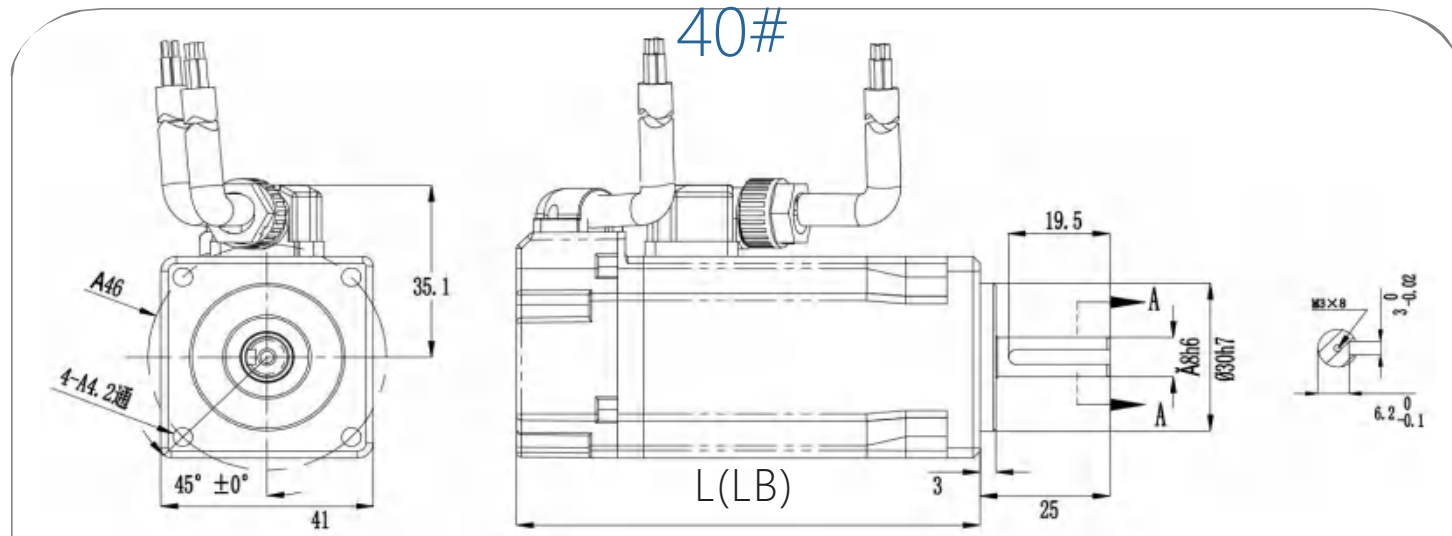

L(mm)	82/88
LB(With brake)mm	102/108
Weight(KG)	0.5/0.65

60#

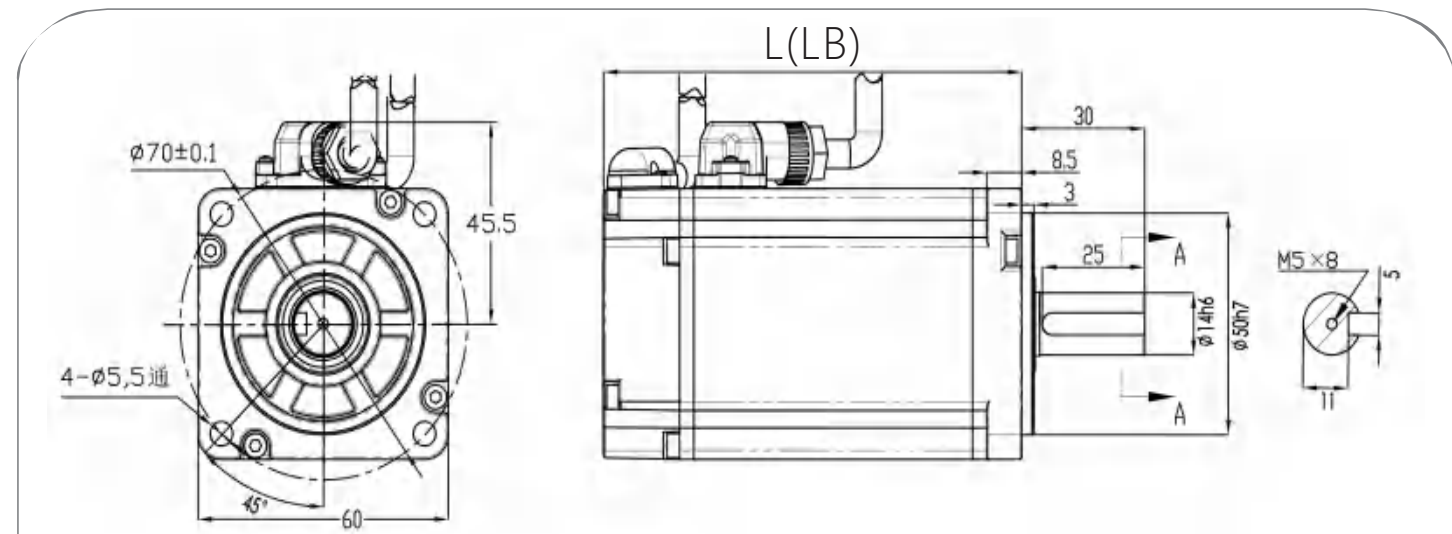

L(mm)	77/92	97/111	115/129	115/129
LB(With brake)mm	116/130	135/149	153/167	165/179
Weight(KG)	1/1.35	1.35/1.75	1.75/2.15	1.75/2.15

Motor external dimensions

External Dimension

80#

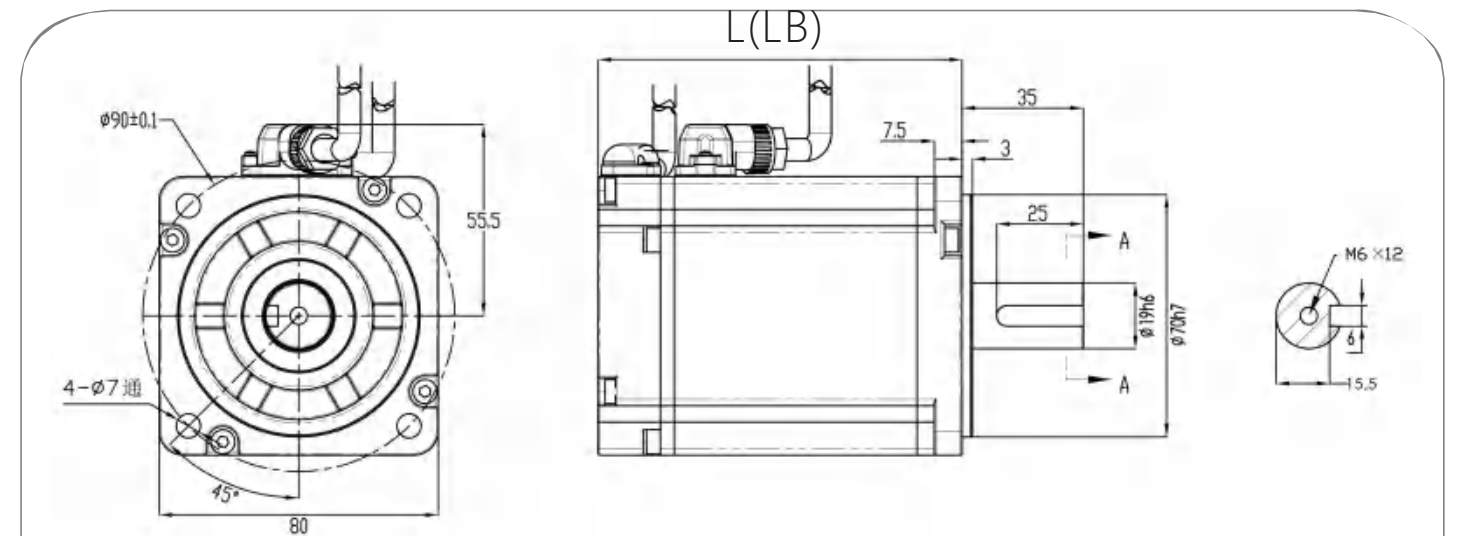

L(mm)	106/120	120/134	71/85	81/95	91(106)	106(120)	120/134
LB(With brake)mm	145/159	159/173	110/124	120/134	130(144)	145(159)	159/173
Weight(KG)	2.3/3.05	2.95/3.6	1.1/1.9	1.8/2.6	1.8/2.6	2.3/3	2.85/3.7

110#

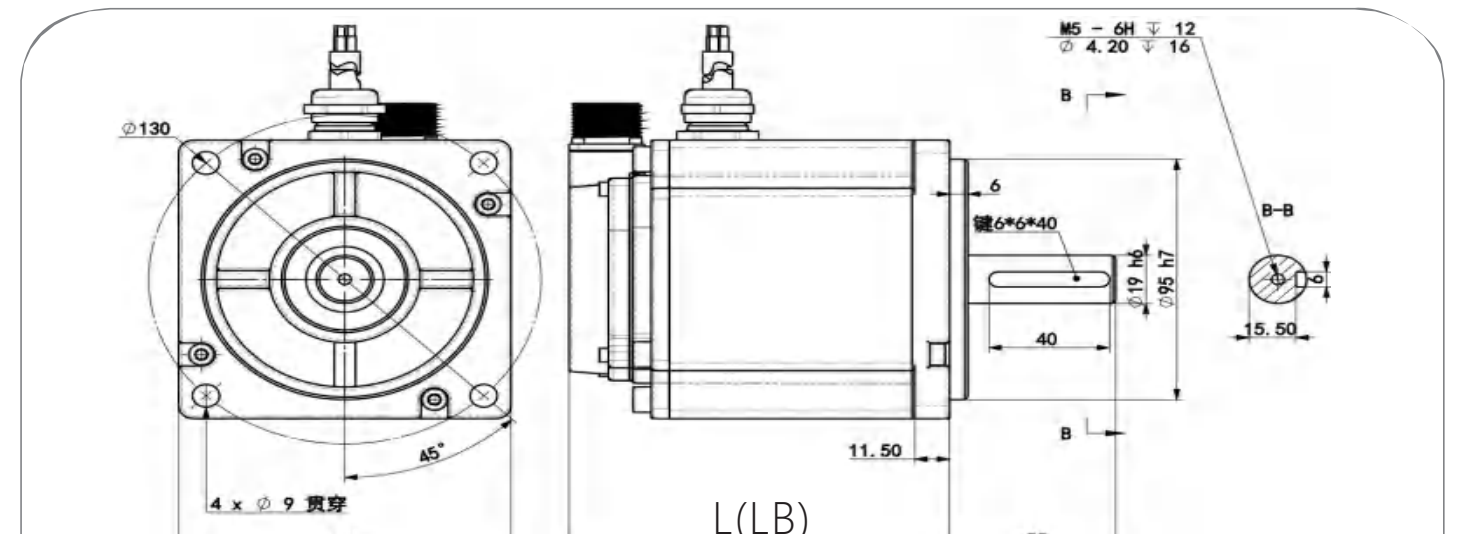

L(mm)	126/139	156/169	171/184
LB(With brake)mm	171/184	193/206	/
Weight(KG)	4.14/6.25	6.36/8.47	8.5

Motor external dimensions

External Dimension

130#

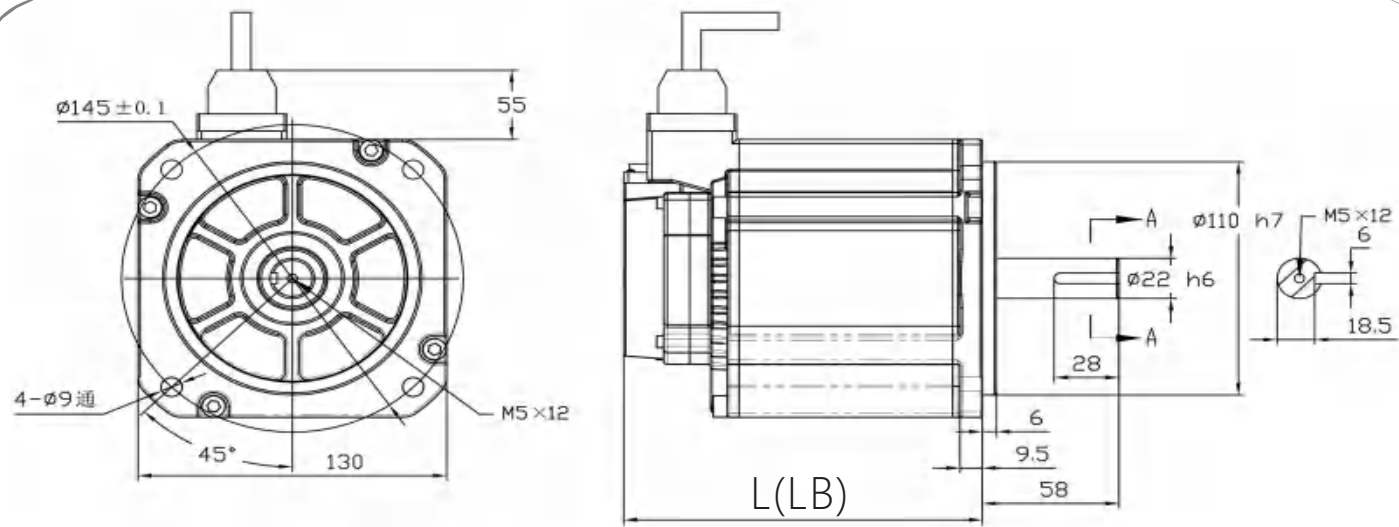

L(mm)	119/132	134/147	134/147	149/162	166/179	181/194
LB(With brake)mm	166/179	181/194	196/209	196/209	221/234	221/234
Weight(KG)	6/7.8	8/9.8	8/9.8	8/9.8	11/12.8	14/15.8

130#With fan

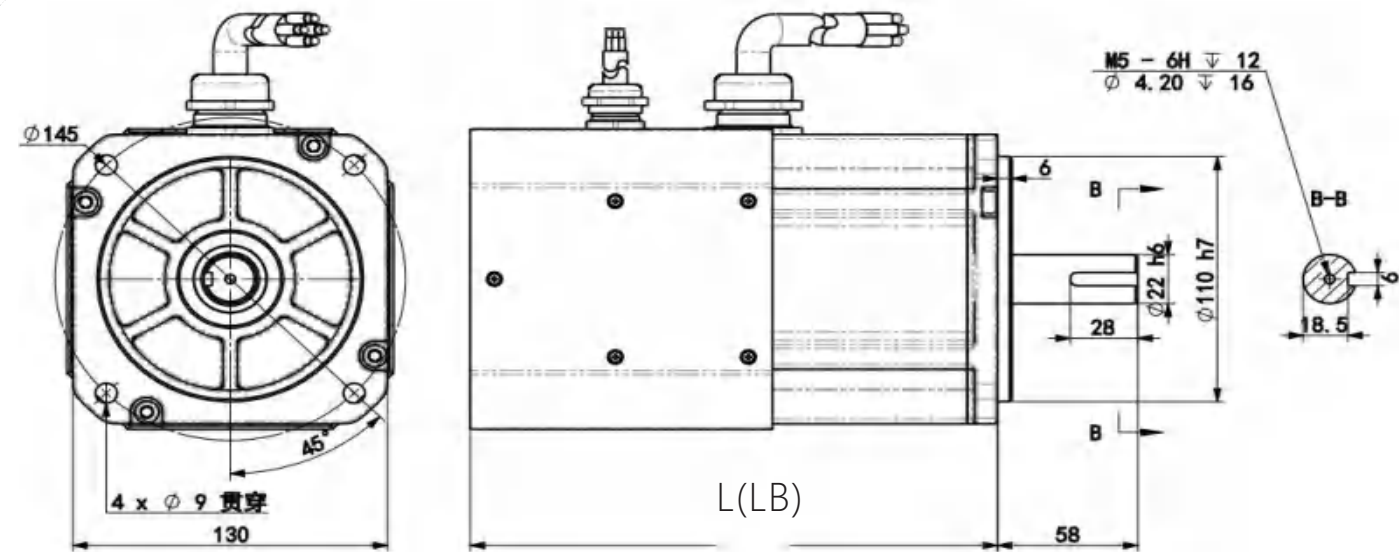

L(mm)	220(233)	220(233)	235(248)	235(248)
LB(With brake)mm	260(273)	260(273)	260(273)	260(273)
Weight(KG)	9/10.8	9/10.8	12/13.8	16/17.8

Motor external dimensions

External Dimension

180#

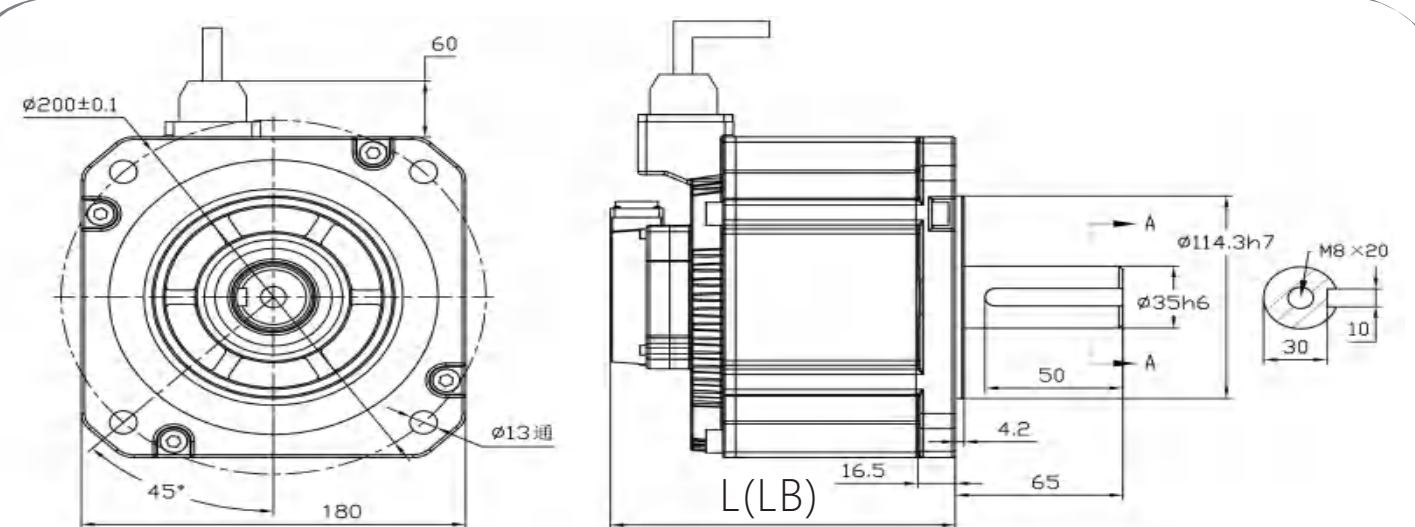

L(mm)	183	213	238	238	276	331
LB(With brake)mm	276	276	276	331	331	/
Weight(KG)	14.5/32	18.9/32	22.7/32	22.7/34	32/34	34

180#With fan

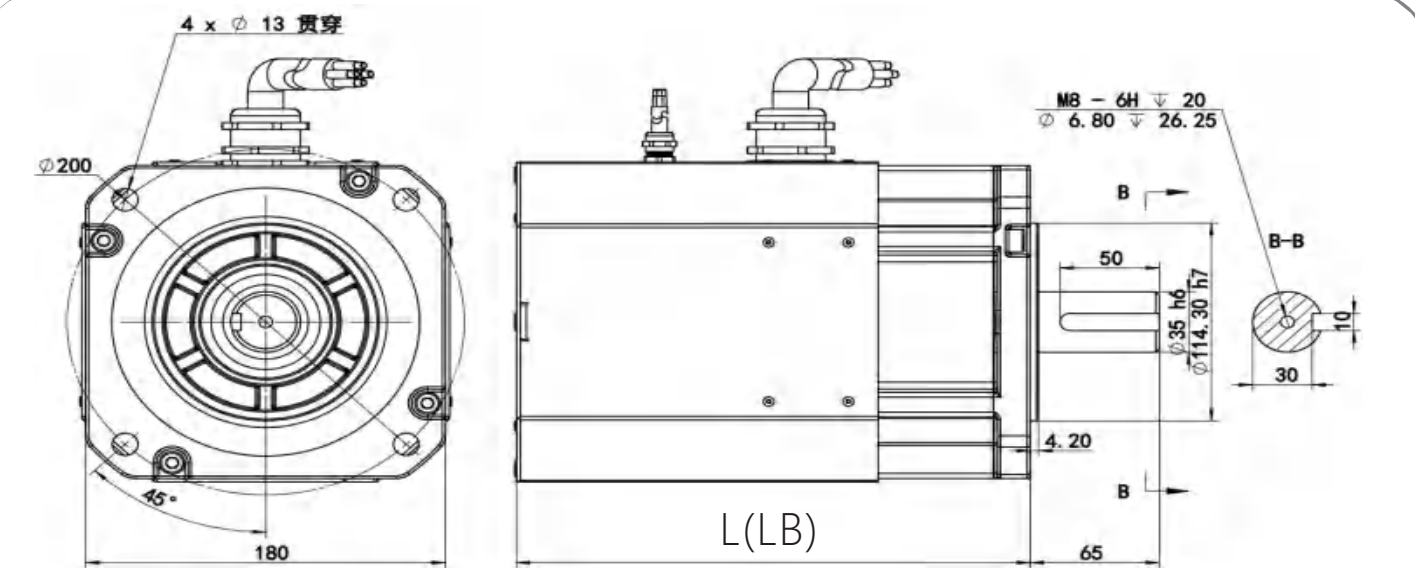

L(mm)	268	293	331
LB(mm)With brake	331	386	386
Weight(KG)	20/34	24.7/36	34/36